

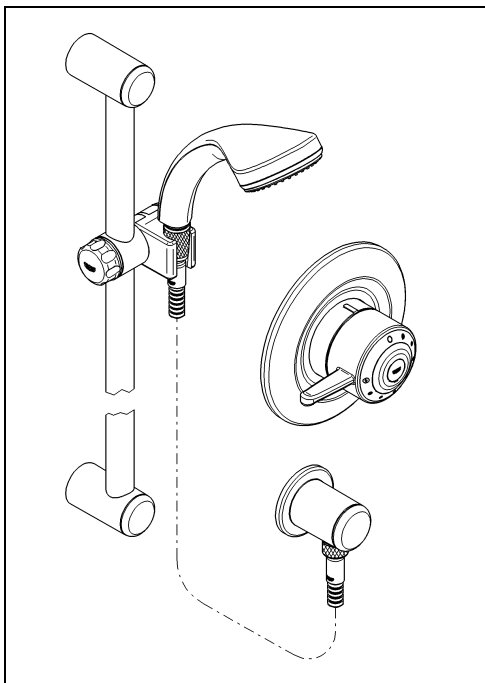

WATER TECHNOLOGY

Avensys

Concealed Single Thermostat Mixing Valve



34 039

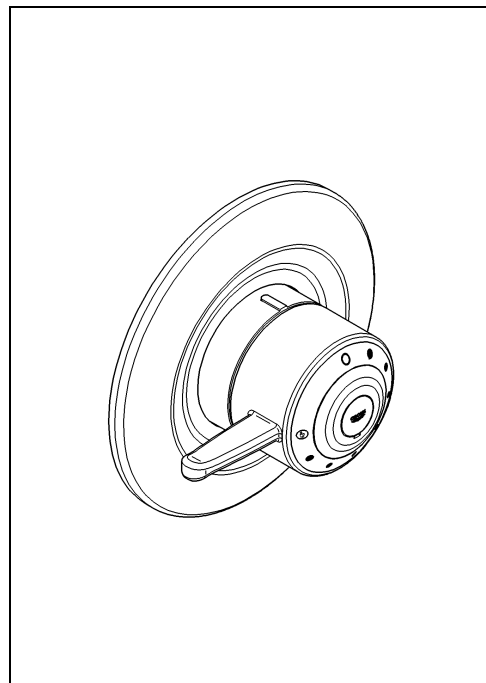

34 041

Installation Instructions and Operating Guide

Please leave this document with the user after finishing installation!

Table Of Contents

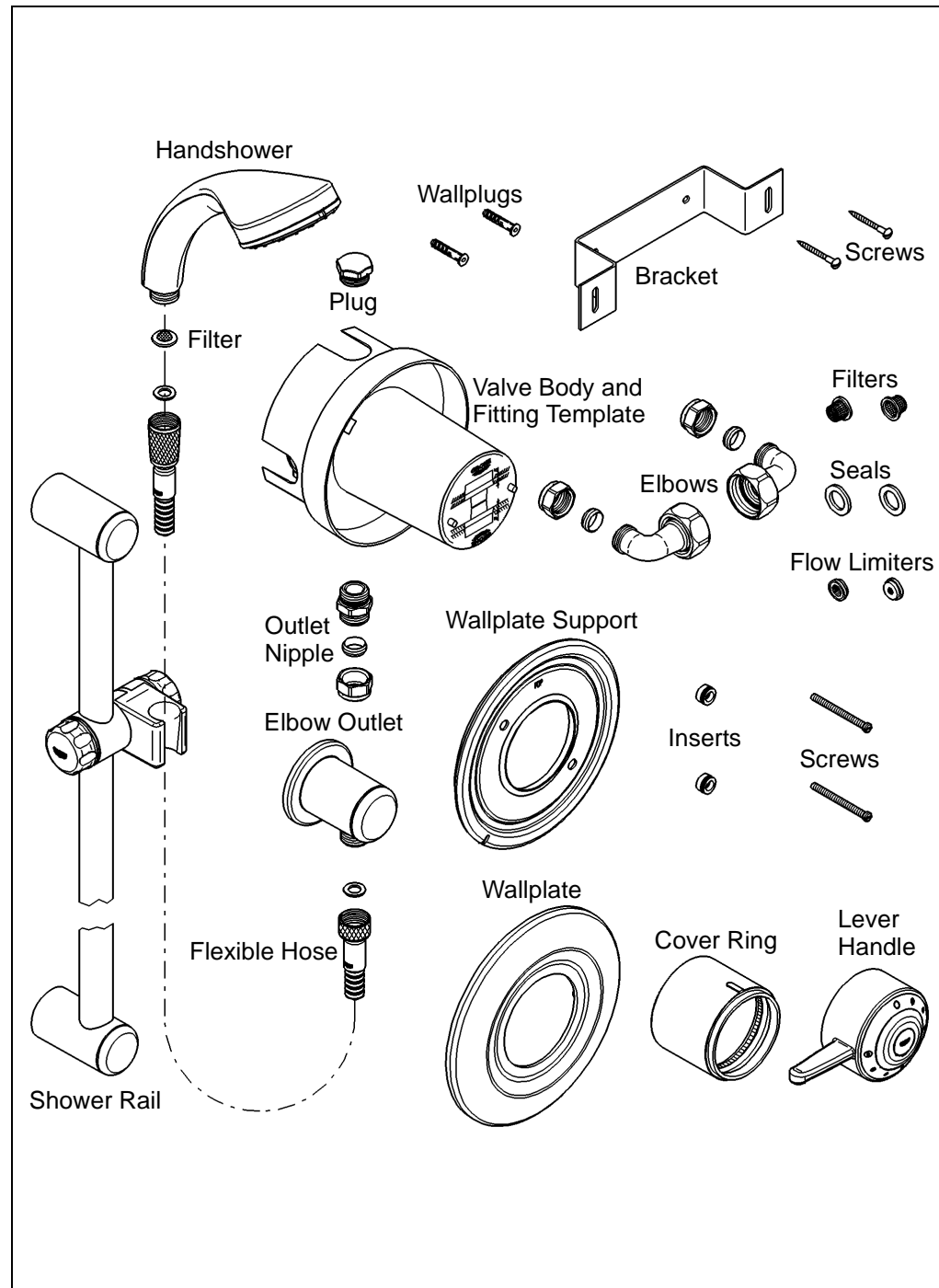

1

Installation Dimensions (mm)

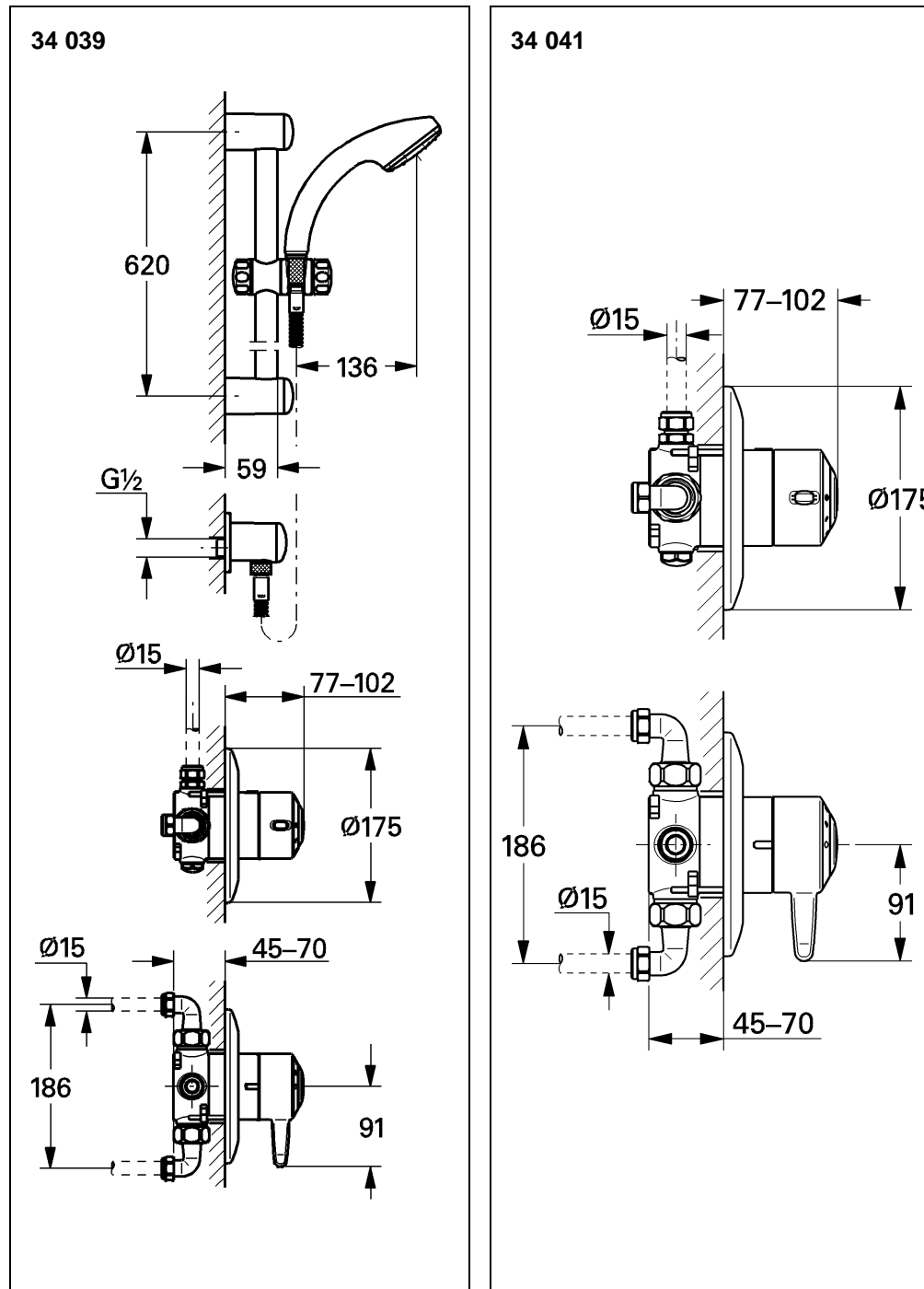

2

Spare Parts

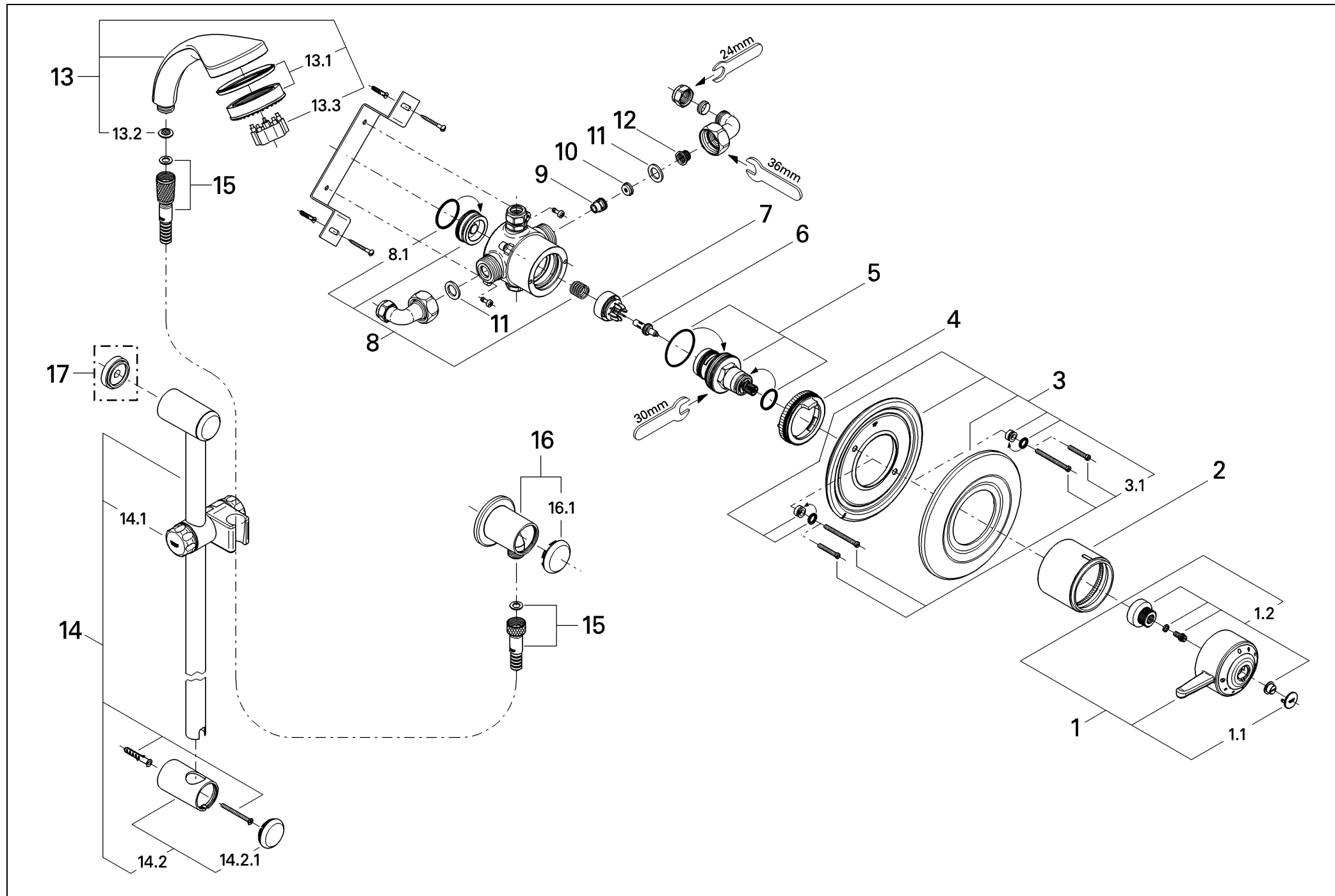

3

4

Index

Table Of Contents	1
Installation Dimensions	2
Spare Parts Drawing	3 + 4
Spare Parts List	5
Technical Data	6
Installation	7
Rough Installation	7
Preassemble Valve	8
Connect Valve	9
Adjustment	10
Wallplate Installation	11
Maintenance	12
Care	14
Trouble Shooting	14
Installation & Operating Instructions	15
Guarantee	17

Dear Customer,

Thank you for choosing a GROHE product. Please follow these instructions carefully and you will enjoy many years of reliable service from this fitting.

Spare Parts

No.	Description	Cat.-No.	Pack- ing unit	No.	Description	Cat.-No.	Pack- ing unit
1	Lever handle complete	47 596	1	12	Filter	06 995	2
1.1	Cap	00 090	1	13	Handshower	28 213	1
1.2	Fixing set	47 592	1	13.1	Shower spray plate	45 793	1
2	Cover ring	01 239	1	13.2	Filter	07 002	2
3	Wall plate complete	46 455	1	13.3	Dismounting key	45 654	1
3.1	Screw	09 361	2	14	Shower rail	28 666	1
4	Stop ring	47 593	1	14.1	Sliding shower holder	07 659	1
5	Control unit	47 600	1	14.2	Shower rail holder	45 362	1
6	Wax element	00 798	1	14.2.1	Cover cap	45 363	1
7	Slider	07 587	1	15	Flexible hose	28 161	1
8	Seat with spring	47 594	1	16	Elbow outlet	28 671	1
8.1	O-ring seal	03 169	5	16.1	Cover cap	45 364	1
9	Non-return valve	06 544	2				
10	Flow limiter set	46 428	1		Optional accessory		
11	Seal	01 386	10	17	Compensation ring	45 406	1

Technical Data

Functioning Principle

This **Avensys** mixing valve is a thermostatic mixer with wax cartridge. Turning the lever handle in a counter-clockwise direction opens the water flow from cold to hot.

This product is supplied with connectors to fit \varnothing 15mm pipework. Connection should be hot left, cold right as viewed from the operating position.

Plumbing Systems

This thermostatic mixing valve is suitable for installation with:

- Gravity-fed plumbing systems with an open vented hot water cylinder
- Cold water storage cistern
- Mains pressure unvented and instantaneous thermal hot water storage systems
- Multi-point gas water heaters
- Combination boilers with a modulating hot water output
To maintain sufficient hot water output ensure the combination boiler temperature setting is on **high**.

Supply Pipework

Ensure the supply pipework is thoroughly flushed before installing the mixing valve. GROHE recommends installing isolating valves upstream of the mixing valve for servicing purposes.

New Water Regulations

This GROHE-product should be installed to comply with the New Water Regulation covering backflow prevention. It must also be installed in accordance with local bye-law requirements.

Specification

- Concealed thermostatic shower mixing valve
- Flow pressure
 - Low pressure 0.1 - 1 bar
 - High pressure 1 - 10 bar

- Avoid major pressure differences between hot and cold water supply:
For different supply pressures use enclosed flow limiters, see chapter "**Prassemble Valve**" on page 8.

- Max. operating pressure 10 bar
- Max. test pressure 16 bar
- Mixed water flow rate:

Pressure	0.1	0.2	0.3	0.4	0.5	0.6	bar
34 039	5.3	7.7	9.9	11.4	12.8	14	l/min
34 041	7.5	10.5	14	17	18.5	21	l/min

- Temperature
 - Max. (hot water inlet) 80 °C
 - Recommended (for economy) 60 °C
 - Maximum temperature is reached when the lever handle is rotated 270° in a counter-clockwise direction.
- Water connection
 - Hot water: red marking = left
 - Cold water: blue marking = right

Installation

Rough Installation

The thermostatic shower mixing valve can be installed in two different ways. The mixing outlet can be at the bottom for use with a handshower or at the top for use with a headshower.

The concealed thermostatic shower mixing valve is supplied with a bracket.

- With bracket mounted from the front the valve can be used for installation into solid and dry-lined walls.
- With bracket mounted from behind the wall the valve can be used for installation into the front face of a stud partition wall structure or the rear face of a shower cubicle or laminated panel.

Solid and dry-lined walls

Determine the route for the incoming hot and cold water supply and for the outlet pipe-work in accordance with the thermostatic shower mixing valve.

1. Mark a 150mm diameter hole for the valve and mark the fixing hole positions for the bracket (A), see Fig. [1].

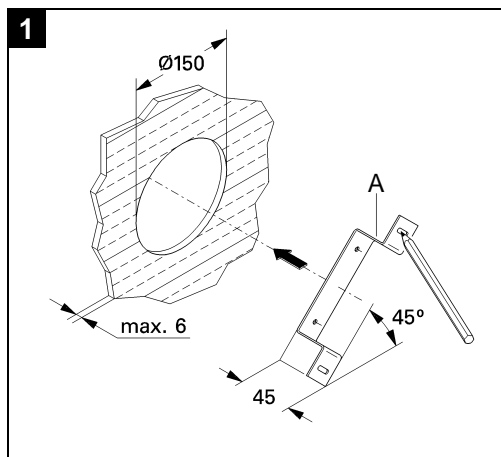

2. Drill 6mm diameter holes and insert the supplied wallplugs (A1), see Fig. [2].

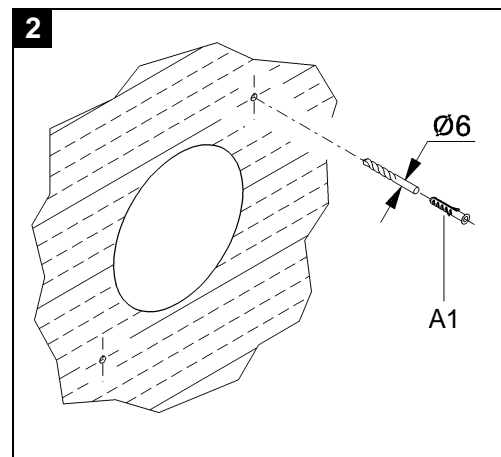

3. Remove the plaster and brick or block.

Laminated panel walls

Determine the route for the incoming hot and cold water supply and for the outlet pipe-work in accordance with the thermostatic shower mixing valve.

1. Mark a 150mm diameter hole for the valve and mark the fixing hole positions for the bracket (A), see Fig. [3].

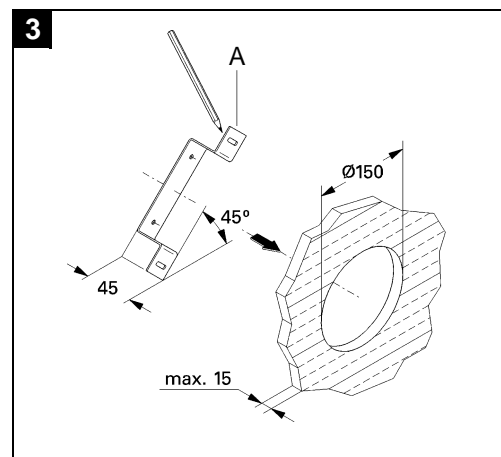

Installation

Preassemble Valve

1. Remove the two screws (B1) from the fitting template (B), then remove the template, see Fig. [4].

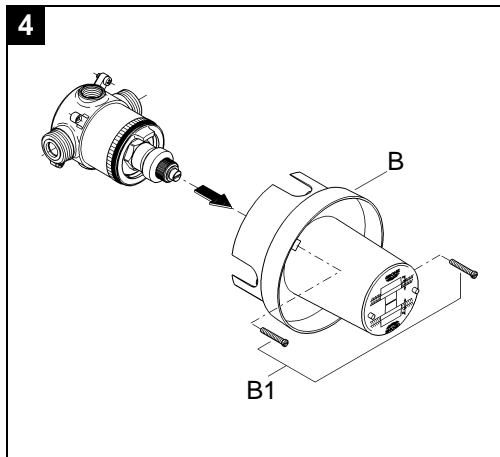

2. Close free outlet with plug (C), see Fig. [5].

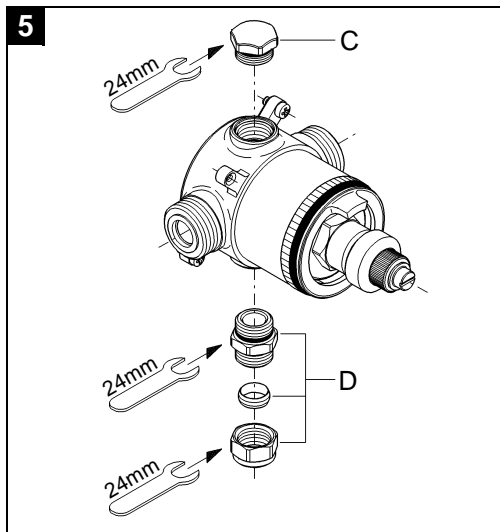

3. Thread the outlet nipple (D) with the O-ring seal into the valve body outlet.

4. Screw valve body (E) to bracket (A) with fixing screws (E1), see Fig. [6].

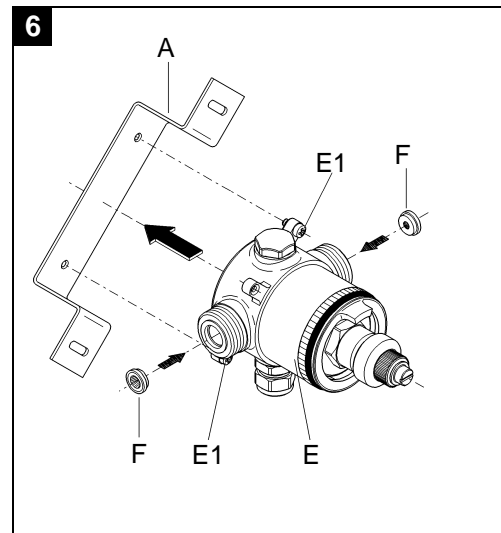

5. If there is a pressure differences between the hot and cold water supply install attached flow limiters (F) in the water connection elbows, see table below.

Cold Water Inlet	Warm Water Inlet	Connection	
		Cold	Warm
0.1 - 1 bar	0.1 - 1 bar	without	without
1 - 5 bar	1 - 5 bar	7 l (green)	5 l (yellow)
1.5 - 10 bar	0.1 - 0.5 bar	7 l (green)	without
	> 0.5 bar	7 l (green)	5 l (yellow)

For **reversed supplies installation** the complete mixing valve must be rotated 180°.

Therefore stop ring must be dismantled, rotated 180° and reinstalled with catch on top.

Installation

Connect Valve

1. Connect elbows (G) onto the supply pipes, see Fig. [7].

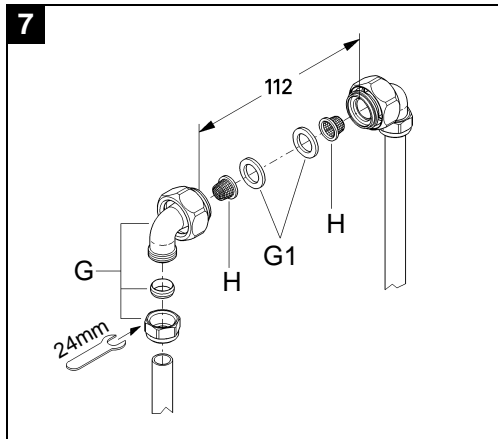

2. Install filters (H) and seals (G1) into the elbows (H).
3. Fix bracket (A) and valve (E) with screws (A1) between the elbows to the wall, see Fig. [8].

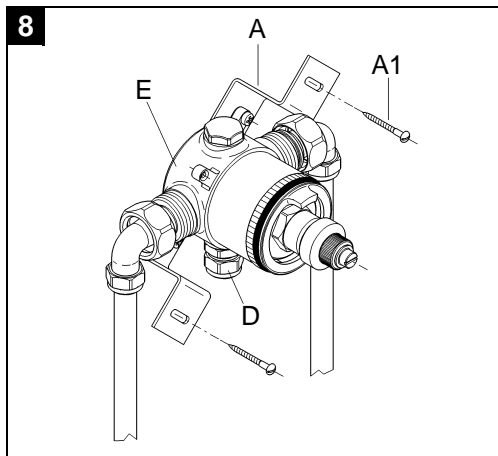

4. Connect mixed water supply to the outlet nipple (D).

The hot water supply must be connected on the left and the cold water supply on the right.

5. Connect elbows (G) to valve body (E) and tighten nuts (G2) [torque min. 20 Nm], see Fig. [9].

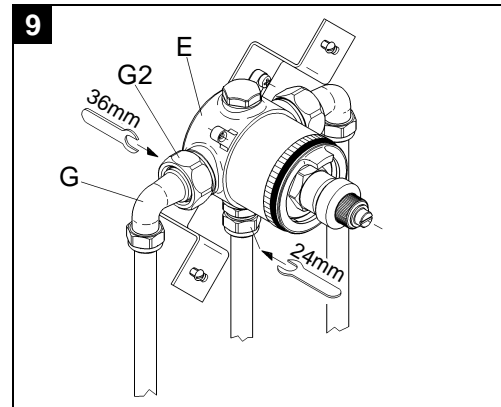

Open hot and cold water supply.

Check the pipework and connections to the thermostat mixing valve for leaks.

6. Reinstall fitting template for finishing wall surface as described in Fig. [4] in reversed direction.
7. Observe the installation depth in accordance with the instructions given on the fitting template, see Fig. [10].

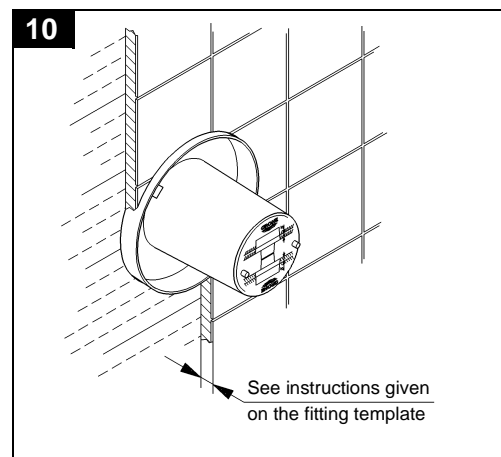

Plaster and tile the wall.

Do not remove fitting template before installation is completed.

Installation

Adjustment

The temperature of the outflowing water is factory set to 43 °C. A temperature adjustment is necessary if:

- The maximum water temperature measured at the outlet varies from the factory set temperature.
- After any maintenance operation on the thermostatic cartridge.

For temperature adjustment please proceed as follows:

1. Remove the two screws (B1) from the fitting template (B), then remove the template, see Fig. [11].

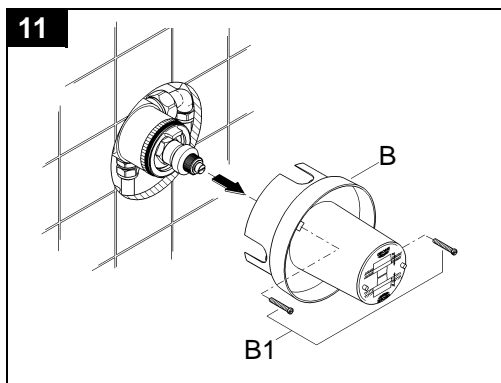

2. Turn the adapter (J) counter-clockwise to fully open position and open water flow, see Fig. [12].

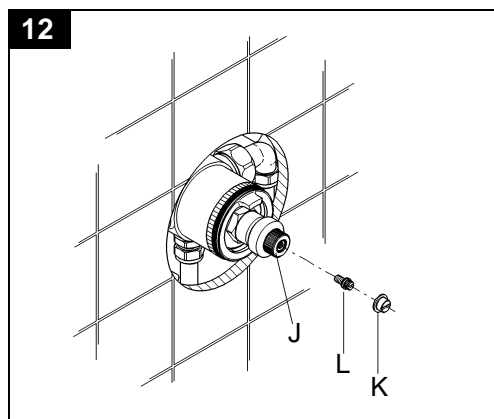

3. Unscrew screw nut (K).
 4. Remove screw (L).
- A small rinse of water drops out.**
5. Check the temperature of the outflowing water with a thermometer, see Fig. [13].

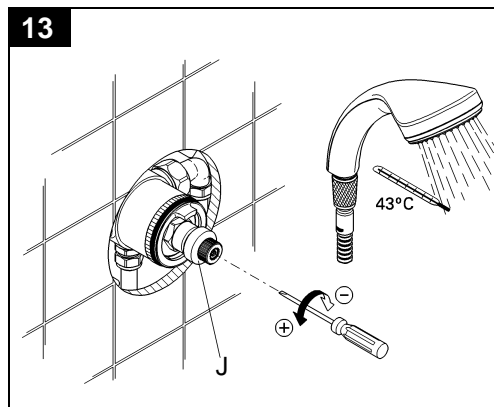

6. With a small screw driver adjust temperature to 43 °C. Turn clockwise (to reduce temperature) or counter-clockwise (to increase temperature).
7. Close control unit by turning the adapter (J) clockwise.
8. For installation wallplate, see chapter **“Wallplate Installation”** on page 11.

Installation

Wallplate Installation

1. Reinstall screw (L) in control unit, see Fig. [14].

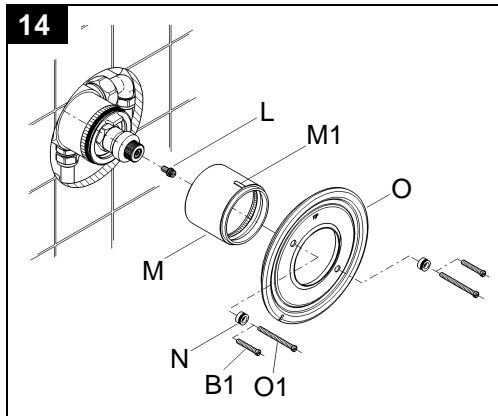

2. Push on cover ring (M) with mark (M1) on top.
3. Place inserts (N) in the wallplate support (O).
4. Slide the wallplate support (O) over the cover ring (M) in position **TOP**.
Additionally seal the top edge of the wallplate support with silicone if it is fitted against a particularly rough surface (deep tile joints, highly textured tile).

5. Tighten wallplate support (O) with two of the four screws [(B1) = template screws or (O1)] into the valve body. These screws allow for variation in wall thickness when mounting the wallplate.

Check correct position of the seal in the wallplate.

6. Snap wallplate (P) into the wallplate support (O), see Fig. [15].

To ensure that the wallplate is correctly seated, lug (P1) must engage in the recess (O2) on the wallplate support.

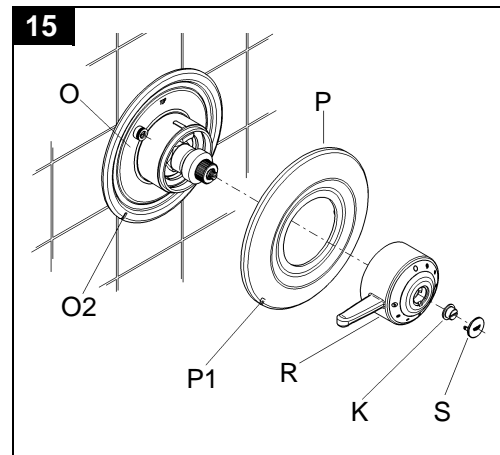

7. Push on lever handle (R) in closed position.
8. Fix lever handle with screw nut (K) and cover with cap (S).

The thermostat mixing valve is now ready for use.

Maintenance

I. Control Unit

1. Shut off hot and cold water supply!
2. Turn the lever handle counter-clockwise to fully open position.
3. Lever out cap (S), see Fig. [16].

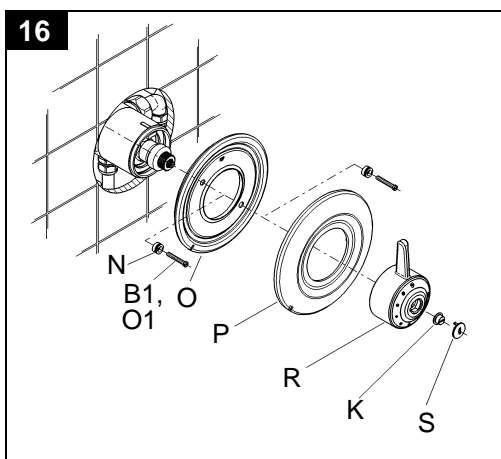

4. Unscrew screw nut (K).
5. Pull off lever handle (R).
6. Pull off wallplate (P).
7. Unscrew screws (B1 or O1) and take out inserts (N).
8. Remove wallplate support (O).
9. Unscrew connections, fixing screws (E1) and take valve (E) from the supplies, see Fig. [17].

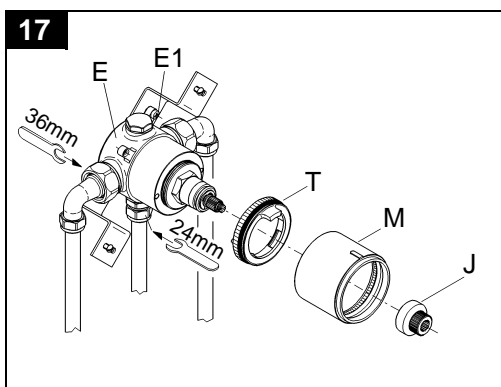

10. Pull off adapter (J).
11. Pull off cover ring (M) and stop ring (T).

12. Screw out control unit (U), see Fig. [18].

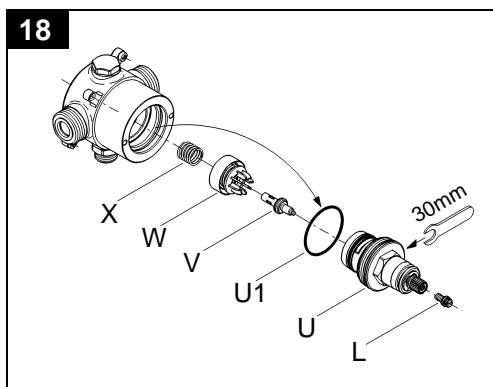

13. Take out O-ring seal (U1).
14. Screw out screw (L) if replacing control unit (U).
15. Take out wax element (V), slider (W) and spring (X).

Inspect and clean all parts, replace if necessary and grease with special valve grease (ref. No. 18 012).

Reinstall control unit

1. Unscrew seat (Y) with O-ring, see Fig. [19].

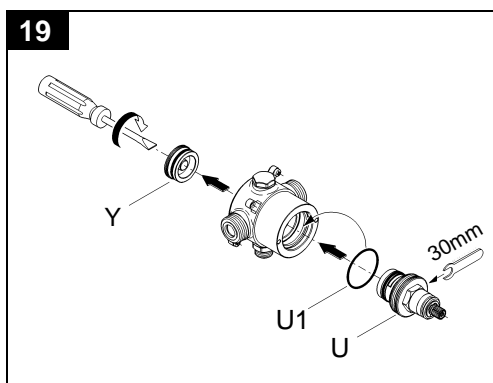

2. Reinstall O-ring seal (U1).
3. Screw in control unit (U).

Maintenance

4. Reinstall wax element (V), slider (W) and spring (X) from behind, see Fig. [20]

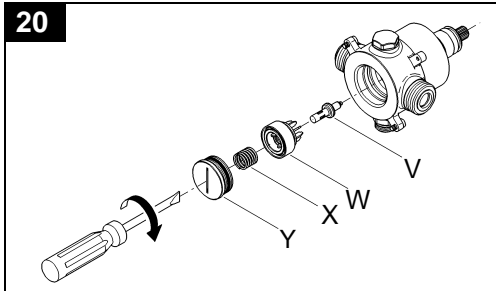

5. Tighten seat (Y) in the valve body.
6. Unscrew seat a half turn (180°), see Fig. [21].

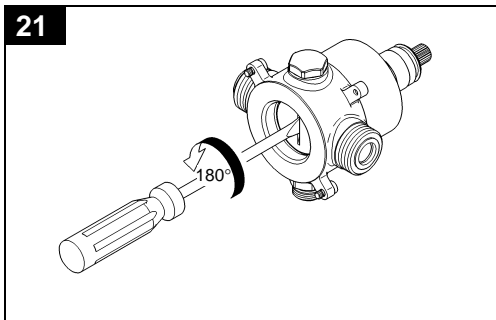

7. Connect elbows (G) to valve body (E) and tighten compression nuts, see Fig. [22].

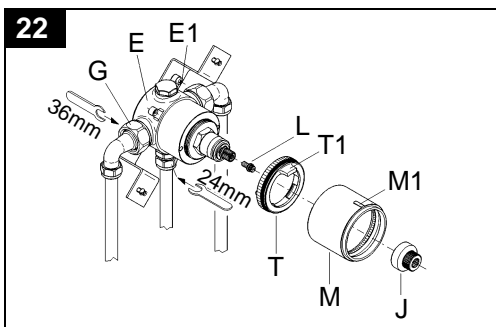

8. Connect mixed water supply.
9. Tighten fixing screws (E1).
10. Push on stop ring (T) with catch (T1) on top.

11. Reinstall cover ring (M) with mark (M1) on top.
12. Push on adapter (J) and close control unit by turning the adapter clockwise. Readjustment is necessary after every maintenance operation on the control unit, see chapter “**Adjustment**” on page 10.
13. Reinstall screw (L) in control unit.
14. Place inserts (N) in the wallplate support (O), see Fig. [23].

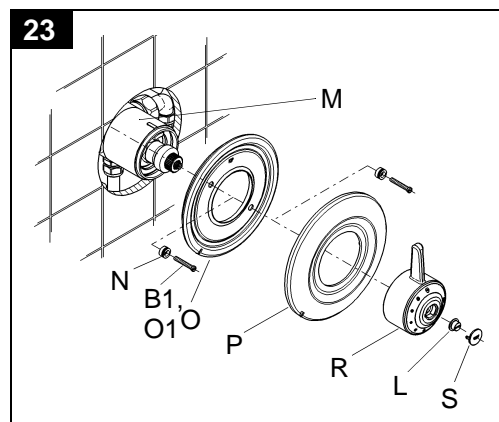

15. Slide the wallplate support (O) over the cover ring (M) in position **TOP**.
16. Tighten wallplate support (O) with screws (B1 or O1) into the valve body.
17. Snap wallplate (P) into the wallplate support (O).
18. Reinstall lever handle (R) in closed position.
19. Fix lever handle with screw nut (N) and cover with cap (M).

II. Non-return valve, see spare parts drawing on page 3, 4, and Fig. [13].

1. Same procedure as for control unit, see Figs. [16] and [17], points 1 to 9.
2. Unscrew elbows, see spare parts drawing on page 3 and 4.
3. Remove flow limiter (10) if installed.
4. Take out and replace non-return valve (9).
Reassemble in reverse order.
Only genuine GROHE replacement parts must be used.

Care

We want to ensure that you get long-lasting satisfaction and pleasure from your GROHE fitting. Therefore, please read the following care instructions because damage to the surface and underlying material resulting from improper treatment is not covered by guarantee.

Do not use any abrasive sponges or scouring agents for cleaning. We also advise not to use cleaning agents containing solvent or acid, limescale removers, household vinegar and cleaning agents with acetic acid. They are aggressive to the surface and will leave

your fitting dull and scratched. As the formulations of commercially available cleaning agents frequently change, we cannot guarantee they will provide the gentle care our fitting deserves.

Clean the fitting with a little soap and a moist cloth only, then simply rinse off and wipe dry. You can avoid lime spots by drying the fitting each time it is used. If lime deposits do occur, remove them with **Grohclean** (ref. no. 18 078), our environment-friendly cleaning liquid. **Grohclean** is specially formulated to gently clean the surface of our fittings.

Trouble Shooting

Problem	Cause	Remedy
Thermostatic valve opens through hot	Hot and cold water supplies have been connected in reverse	Rotate the thermostatic mixing valve
Range of temperature adjustment restricted	High pressure difference between hot and cold water supply	Install flow limiter see chapter Exposed Installation
Shower insufficiently cold or hot	Adjustment incorrectly set Hot water supply temperature too low	Refer to the instructions in chapter Adjustment Check hot water source temperature setting
No flow of hot or cold water	Either the hot or cold side is not fully pressurized Debris caught inside the inlet of the control unit	Replace non-return valve, refer to chapter Maintenance Remove mixing valve and flush out or remove any debris lodged inside the hot or cold inlets or filters
Hot water emerges to cold water supply or vice versa	Non return valves are damaged in cause of lime	Replace non-return valve, refer to chapter Maintenance

Re. Installation & Operating Instructions

For Product 34 041 only!

The product must be installed with isolating valves for maintenance and in-service testing.

Before commissioning, GROHE recommends simulating at least 12 alternate hot and cold water failures before final adjustment of the mixed water set temperature.

No maintenance other than cleaning the filters should be carried out on this product.

1. Commissioning and in-service tests

1.1 Commissioning

1.1.1 Purpose

Since the installed supply conditions are likely to be different from those applied in the laboratory tests it is appropriate, at commissioning, to carry out some simple checks and test on each mixing valve to provide a performance reference point for future in-service test.

1.1.2 Procedure

1.1.2.1 Check that:

- the designation of the thermostatic mixing valve matches the intended application.
- the supply pressures are within the range of operating pressures for the designation of the valve.
- the supply temperatures are within the range permitted for the valve and by guidance information on the prevention of legionella etc.

1.1.2.2 Adjust the temperature of the mixed water in accordance with the manufacturer's instructions 41°C maximum for shower and wash basin and the requirement of the application and then carry out the following sequence.

- record the temperature of the hot and cold water supplies.
- record the temperature of the mixed water at the largest draw-off flow rate.
- record the temperature of the mixed water at a smaller draw-off flow rate, which shall be measured.
- isolate the cold water supply to the mixing valve and monitor the mixed water temperature.
- record the maximum temperature achieved as a result of
- and the final temperature. NOTE. The final mixed water temperature should not exceed the values in Table 1, and any higher temperature should occur only briefly.
- record the equipment, thermostat etc. used for the measurements.

Table 1: Guide to maximum continuous temperatures during site tests.

Application	Mixed water temperature °C
High- /Low Pressure Shower	43
High- /Low Pressure Washbasin	43

1.2 In-service tests

1.2.1 Purpose

The purpose of in-service tests is to regularly monitor and record the performance of the thermostatic mixing valve. Deterioration in performance can indicate the need for service work on the valve and/or the water supplies.

Re. Installation & Operating Instructions

1.2.2 Procedure

1.2.2.1 Carry out the procedure 1.1.2.2 (a) to (c) using the same measuring equipment, or equipment to the same specification.

1.2.2.2 If the mixed water temperature has changed significantly from the previous test results (e.g. > 1K), record the change and before re-adjusting the mixed water temperature check

- a) that any in-line or integral strainers are clean.
- b) any in-line or integral check valves or other anti-backsiphonage devices are in good working order.
- c) any isolating valves are fully open.

1.2.2.3 With an acceptable mixed water temperature, complete the procedure 1.1.2.2(a) to (f).

1.2.2.4 If at step 1.1.2.2 (e) the final mixed water temperature is greater than the values in Table 1 and/or the maximum temperature exceeds the corresponding value from the previous test results by more than about 2 K, the need for service work is indicated.

NOTE:

In-service tests should be carried out with a frequency which identifies a need for service work before an unsafe water temperature can result. In the absence of any other instruction or guidance, the procedure described in Annex F may be used.

Frequency of in-service tests

F.1 General

In the absence of any other instruction or guidance on the means of determining the appropriate frequency of in-service testing, the following procedure may be used:

F.1.1 6-8 weeks after commissioning carry out the tests given in 1.2.2.

F.1.2 12-15 weeks after commissioning carry out the tests given in 1.2.2

F.1.3 Depending on the result of F.1.1. and F.1.2 several possibilities exist:

- a) If no significant changes (eg. < 1 K) in mixed water temperatures are recorded between commissioning and F.1.1 or between commissioning and F.1.2 the next in-service can be deferred to 24 to 28 weeks after commissioning.
- b) If small changes (eg. 1 to 2 K) in mixed water temperatures are recorded in only one of these periods, necessitating adjustment of the mixed water temperature, then the next in-service test can be deferred to 24 to 28 weeks after commissioning.
- c) If small changes (eg. 1 to 2 K) in mixed water temperatures are recorded in both of these periods, necessitating adjustment of the mixed water temperature, then the next in-service test should be carried out at 18 to 21 weeks after commissioning.
- d) If significant changes (eg. > 2 K) in mixed water temperatures are recorded in either of these periods, necessitating service work, then the next in-service test should be carried out at 18 to 21 weeks after commissioning.

F.1.4 The general principle to be observed after the first 2 or 3 in-service tests is that the intervals of future tests should be set to those which previous tests have shown can be achieved with no more than a small change in mixed water temperature.

Guarantee

Guarantee declaration

Our products correspond to the valid technical and water supply standards as well as the relevant approvals requirements. We guarantee them to be free of design and production faults at the time of delivery and that with correct use and care in accordance with our printed instructions they will function reliably.

Guarantee period

- The guarantee is valid in private homes for 5 years from the purchase date. Proof of purchase has to be provided when making a guarantee claim.
- By use in commercial or institutional applications the guarantee is valid for 1 year after first use. An extension of the guarantee up to 5 years can be achieved by showing that the product is professionally maintained each year.

To make a guarantee claim, proof of purchase or, the beginning of use is required. The guarantee period is not renewed or increased through supply of spare parts or repair during the guarantee period. The guarantee period for purchased spare parts is the same as for original products.

Guarantee performance

- A) During the whole guarantee period we will correct all functional defects for which we are responsible (limitations see E + F).
- B) It is our option if we correct the defects by repair or replacement.
- C) During the above guarantee period we will not charge for the cost of parts, travel, working time, freight and packaging needed to effect the correction of defects.
- D) If we are not able to correct the defect we are prepared to supply a replacement product.
- E) Deliberate or careless damage is not covered by this guarantee. If the installation, assembly or care instructions that were valid at the time of installation are not followed or the product is used for a purpose other than that given in the written information the guarantee declaration does not apply. Problems caused by dirt, lime-scale or aggressive cleaners are not covered by the guarantee.
- F) The guarantee becomes void if repairs are not carried out competently or spare parts of non GROHE origin are used.
- G) Replaced parts become the property of GROHE and are to be surrendered to our service personnel or sent to our registered offices.

Please enter date of purchase and installation here.

Our address

GROHE Limited
1, River Road
Barking,
Essex, IG11 OHD
GB
Tel.: 0208 / 594 72 92
Fax: 0208 / 594 88 98



© 2000 Friedrich Grohe AG & Co. KG

Friedrich Grohe AG & Co. KG · P.O. Box 1361 · 58653 Hemer/Germany
Tel. (0) 23 72 / 93 - 0 · Fax: (0) 23 72 / 93 13 22