

# ***mira***

Atom

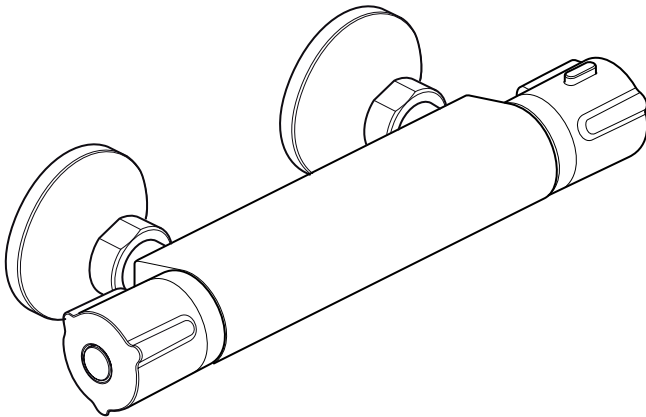

MIRAATOM EV

THERMOSTATIC BAR VALVE

INSTALLATION & USER GUIDE

**These instructions must be left with the user.**

## CONTENTS

<b>Introduction</b>	<b>2</b>
Guarantee	2
Recommended Usage	2
Design Registration	2
<b>Safety Warnings</b>	<b>3</b>
<b>Pack Contents</b>	<b>3</b>
<b>Specifications</b>	<b>4</b>
Pressures	4
Temperatures	4
Thermostatic Shut-down	4
Connections	4
Dimensions	4
<b>Installation</b>	<b>5</b>
Suitable Plumbing Systems	5
General	5
Installing the Thermostatic Mixer	6
<b>Commissioning</b>	<b>7</b>
Maximum Temperature Setting	7
<b>Operation</b>	<b>8</b>
Adjusting the Temperature	8
Adjusting the Flow	8
<b>User Maintenance</b>	<b>8</b>
Fault Diagnosis	8
Lubricants	9
Cleaning	9
Filters	9
Maintaining the Non-Return Valves	9
<b>Spare Parts</b>	<b>10</b>
<b>Notes</b>	<b>11</b>
<b>Customer Service</b>	<b>Back Page</b>

If you experience any difficulty with the installation or operation of your new thermostatic mixer, please refer to '**Fault Diagnosis**', before contacting Kohler Mira Ltd. Our contact details can be found on the back cover of this guide.

## INTRODUCTION

Thank you for purchasing a quality Mira product. To enjoy the full potential of your new product, please take time to read this guide thoroughly, having done so, keep it handy for future reference.

The Mira Atom thermostatic bar valve is a thermostatic shower control designed for wall mount installations.

The thermostatic bar valve has two knobs, one knob controls the flow and the other knob controls the temperature.

The Mira Atom EV is supplied complete with Mira L14A Shower Fittings.

The thermostatic bar valve incorporates a wax capsule temperature sensing unit, which provides an almost immediate response to changes in pressures or temperature of the incoming water supplies, to maintain the selected temperature. An adjustable maximum temperature stop is provided which limits the temperature to a safe level. Inlet filters are fitted to protect the thermostatic cartridge.

### Guarantee

For **domestic installations**, Mira Showers guarantee the Mira Atom against any defect in materials or workmanship for a period of **three** years from the date of purchase (shower fittings for one year).

For **non-domestic installations**, Mira Showers guarantee the Mira Atom against any defect in materials or workmanship for a period of **one** year from the date of purchase.

For terms and conditions refer to the back cover of this guide.

### Recommended Usage

Application	Valve with Fittings
Domestic	✓
Light Commercial	✓
Heavy Commercial	✘
Healthcare	✘

### Design Registration

000793401-0001-0003

## SAFETY WARNINGS

Mira thermostatic mixers are precision engineered and should give continued safe and controlled performance, provided:

1. They are installed, commissioned, operated and maintained in accordance with the manufacturer's recommendations.
2. Periodic attention is given, when necessary, to maintain the product in good functional order.

### Caution!

1. Read all of these instructions.
2. Retain this guide for later use.
3. Pass on this guide in the event of change of ownership of the installation site.
4. Follow all warnings, cautions and instructions contained in this guide.
5. Anyone who may have difficulty understanding or operating the controls of any shower should be attended whilst showering. Particular consideration should be given to the young, the elderly, the infirm or anyone inexperienced in the correct operation of the controls.
6. Rapid/Excessive movement of the flow and/or temperature control levers may result in momentary unstable blend temperatures.
7. Care is required when adjusting flow or temperature, make sure that the temperature has stabilised.
8. When this product has reached the end of its serviceable life, it should be disposed of in a safe manner, in accordance with current local authority recycling, or waste disposal policy.

## PACK CONTENTS

Tick the appropriate boxes to familiarise yourself with the part names and to confirm that all of the parts are included.

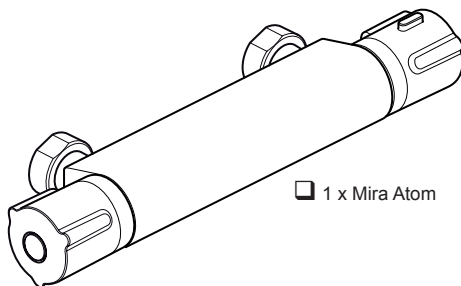

1 x Mira Atom



2 x Concealing Plates



2 x Washers / Filters



2 x Inlet Connectors

### Documentation

1 x Guarantee Registration Document

## SPECIFICATIONS

### Pressures

- Max Static Pressure: **10 Bar**.
- Max Maintained Pressure: **5 Bar**.
- Min Maintained Pressure: (Gas Water Heater): **1.0 Bar** (for optimum performance supplies should be nominally equal).
- Min Maintained Pressure (Gravity System): **0.1 Bar** (0.1 bar = 1 Metre head from cold tank base to showerhead outlet).

### Temperatures

- Close temperature control is provided between **20°C and 50°C**.
- Optimum Thermostatic Control Range: **35°C to 45°C** (achieved with supplies of 15°C cold, 65°C hot and nominally equal pressures).
- Recommended Hot Supply: **60°C to 65°C** (**Note!** The mixing valve can operate at temperatures up to 85°C for short periods without damage. However for safety reasons it is recommended that the maximum hot water temperature is limited to 65°C).
- Minimum Differential between Hot Supply and Outlet Temperature: **10°C**.
- Cold Water Range: **5°C - 25°C**.

### Thermostatic Shut-down

- For safety the thermostat will shut off the hot supply **within 2 Seconds** if the cold supply fails (achieved only if the hot supply temperature is greater than 10°C above the set blend temperature).

### Connections

- **Hot: Left** (side nearest flow control), ½" BSP Male.
- **Cold: Right** (side nearest temperature control), ½" BSP Male.
- **Outlet:** bottom, ½" BSP Male to flexible hose.

**Note!** This product does not allow for reversed inlets and will deliver unstable temperatures if fitted incorrectly.

Offset connector (inlet centres are 150 mm ± 24 mm).

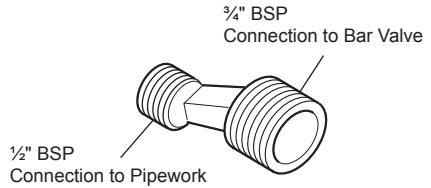

### Dimensions

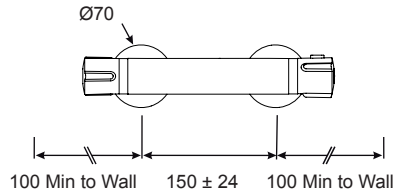

Dimensions in mm

# INSTALLATION

## Suitable Plumbing Systems

### Gravity Fed:

The thermostatic mixer must be fed from a cold water cistern (usually fitted in the loft space) and a hot water cylinder (usually fitted in the airing cupboard) providing nominally equal pressures.

### Gas Heated System:

The thermostatic mixer can be installed with a combination boiler.

### Unvented Mains Pressure System:

The thermostatic mixer can be installed with an unvented, stored hot water system.

### Mains Pressurised Instantaneous Hot Water System:

The thermostatic mixer can be installed with systems of this type with balanced pressures.

### Pumped System:

The thermostatic mixer can be installed with an inlet pump (twin impeller). The pump must be installed on the floor next to the hot water cylinder.

## General

Installation must be carried out in accordance with these instructions, and must be conducted by designated, qualified and competent personnel.

The installation must comply with the "Water Supply Regulations 1999 (Water Fittings)" or any particular regulations and practices, specified by the local water company or water undertakers.

**Note!** Make sure that all site requirements correspond to the information given in section: 'Specifications'.

1. The mixer must not be installed in an area where it may freeze.
2. For stud partitions alternative fixings may be required.
3. Isolating valves must be installed close to the mixer for ease of maintenance.
4. Pipework must be rigidly supported and avoid any strain on the connections.

5. Pipework dead-legs should be kept to a minimum.
6. Decide on a suitable position for the mixer. The position of the mixer and the shower fittings must provide a minimum gap of 25 mm between the spill-over level of the shower tray/bath and the showerhead (refer to illustration). This is to prevent back-siphonage.

**Note!** Only use shower fittings recommended by the manufacturer or supplier.

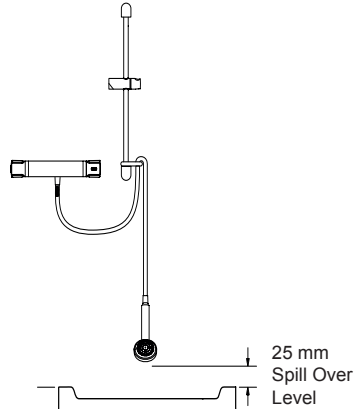

## Installing the Thermostatic Mixer

The thermostatic bar valve should be installed where it will be supported by fixed pipework. For unfixed pipework a wall mounting bracket must be used (available as a spare part, part number: 1663.257, contact Customer Services).

1. Install the pipework, making sure that it is set at the correct distance apart ( $150 \pm 24$  mm) and **solidly fixed**.
2. Apply suitable thread sealant (not supplied) and attach the offset connectors to the pipework in the wall. The offset connectors must protrude between 26 and 30 mm from the finished wall.

**Note!** Connections are: **Hot-Left, Cold-Right**. This is very important as this product does not allow for reversed inlets.

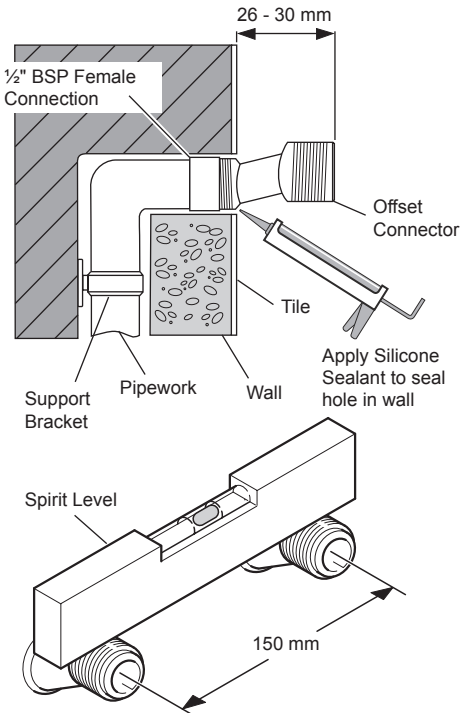

3. Tighten the offset connectors using a spanner on the spanner flats. Make sure that the connectors are level and set at the correct distance apart, using the bar valve as a guide to spacing.

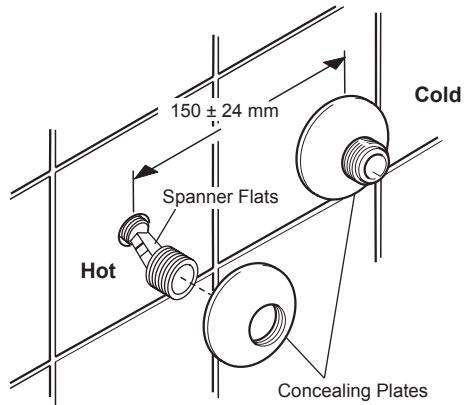

4. Screw the concealing plates onto the offset connectors until they come into contact with the wall.
  5. **Caution!** Make sure that the supply pipework is flushed before installing the Bar Valve. Assemble the bar valve with a sealing washer/filter in each inlet and attach to the offset connectors.
- Note!** Connections are: **Hot-Left, Cold-Right**.

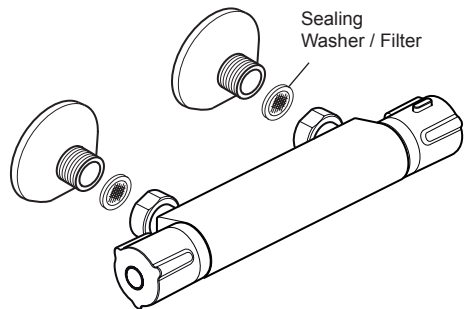

6. Tighten the connections using a suitable spanner.
7. Install the shower fittings, refer to the shower fittings Installation and User Guide.
8. Turn on the hot and cold water supplies and check for leaks.
9. Before using the shower, refer to section: '**Commissioning**'.

# COMMISSIONING

## Maximum Temperature Setting

Before using the shower the maximum temperature must be checked to make sure that it is at a safe level. It has been preset to a safe showering temperature under ideal conditions at the factory, appropriate for most systems. However, site conditions and personal preference may make it necessary to reset this temperature.

**Note!** Make sure that the hot water temperature is at least 55°C and that there is sufficient supply.

**Caution!** Before testing the mixer, make sure that the hot and cold water is flowing correctly by exercising the temperature selector knob between the cold and hot stops.

1. Turn the temperature selector knob to position 7 and test that the temperature of the water from the shower outlet is hot enough.
2. If not, depress the override button and **carefully** rotate towards position 9. If the water temperature is still not hot enough complete the following procedure.
3. Rotate the temperature selector knob back to position 7.
4. Using a suitable screwdriver carefully prise off the concealing cap and unscrew the fixing screw.
5. Pull off the temperature selector knob without disturbing the stop assembly.

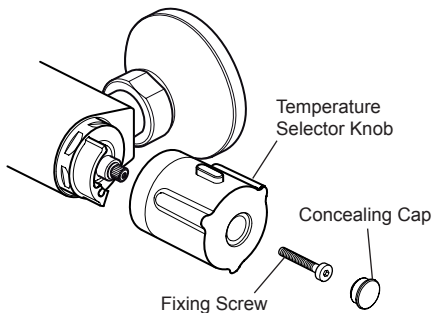

6. Replace the temperature selector knob so that the 6 mark is in line with the stop assembly.
7. Rotate the temperature selector knob to position 7, wait for the water to stabilise and test that the temperature of the water from the shower outlet is hot enough.

If the water temperature is still not hot enough repeat the procedure until a maximum safe temperature is achieved at position 9.

8. Refit and tighten the fixing screw, refit the concealing cap.

## OPERATION

### Adjusting the Temperature

The temperature is controlled by rotating the temperature knob.

For safety reasons, the temperature is limited by an override stop. To obtain a higher temperature, press the override button on the temperature knob and continue to rotate.

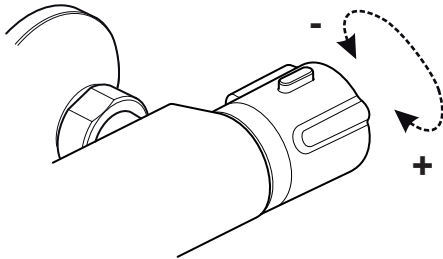

### Adjusting the Flow

The flow is controlled by rotating the flow knob.

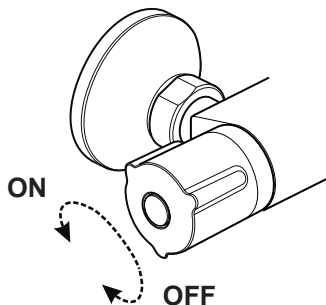

## USER MAINTENANCE

If you require a Mira trained service engineer or agent, refer to section: 'Customer Services'.

### Fault Diagnosis

#### Symptom:

- Only hot or cold water from the mixer outlet.
- Outlet temperature too hot / too cold.

#### Cause / Rectification:

- Inlets reversed (hot supply to cold supply). Rework inlet pipework.
  - No hot or cold water reaching the mixer.
  - Check the filters for any blockage.
  - Installation conditions outside operating parameters, refer to sections: 'Specifications' and 'Commissioning'.
- 

#### Symptom:

- Fluctuating or reduced flow rate.

#### Cause / Rectification:

- Check the showerhead, hose and filters for any blockage.
  - Make sure that the maintained inlet pressures are nominally balanced and sufficient, refer to section: 'Specifications'.
  - Make sure that the inlet temperature differentials are sufficient, refer to section: 'Specifications'.
  - Air lock or partial blockage in the pipework.
- 

#### Symptom:

- Water leaking from showerhead.

#### Cause / Rectification:

- Normal for a short period after shut off.
- Check that the pressures are not in excess of the specifications for the product.
- Cartridge inlet seals damaged, renew.
- Renew the thermostatic cartridge.



## Lubricants

Silicone based lubricants must only be used on the rubber seals.

**Caution!** Oil based or other lubricant types may cause rapid deterioration of seals.

## Cleaning

The chrome plated parts should be cleaned using a mild washing up detergent or soap solution, rinsed and then wiped dry with a soft cloth.

**Warning!** Many household cleaners contain abrasive and chemical substances, and should not be used for cleaning plated or plastic fittings.

**Do not** use descalents on this product.

## Filters

The sealing washers / filters are located in the inlet connector. Clean or renew as necessary.

## Maintaining the Non-Return Valves

The non-return valves are located in the thermostatic bar valve body, and are accessible through the inlet connectors.

**Caution!** Make sure that the non-return valves are installed correctly to prevent crossflow or malfunction of the valve.

1. With the water supplies turned off and the thermostatic bar valve removed, remove the sealing washer / filter.
2. Unscrew the non-return valve housing using a 12 mm hexagonal wrench.  
**Note!** The non-return valve housing has a **Left Hand Thread**, turn clockwise to unscrew.
3. Carefully remove the non-return valve and clean any debris.
4. On re-assembly make sure that the non-return valve is fitted the correct way round (with the arrow indicating the flow pointing towards the valve).

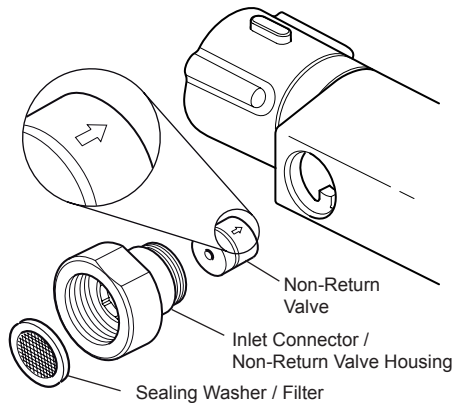

# SPARE PARTS

**Note!** All spare parts are supplied individually unless stated otherwise.

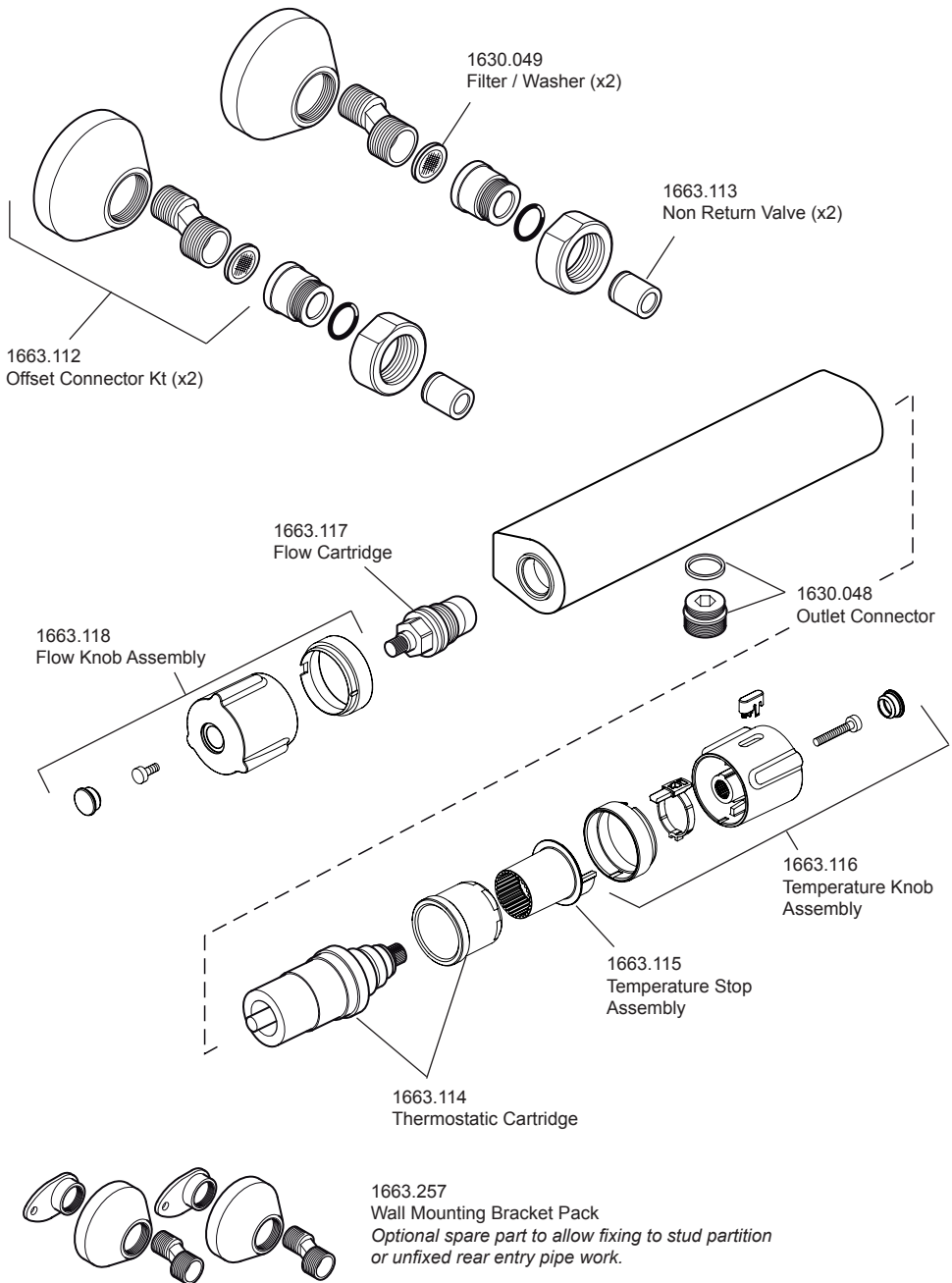

NOTES

# CUSTOMER SERVICE

## Guarantee of Quality

Mira Showers guarantee your product against any defect in materials or workmanship, provided that it is installed and maintained in accordance with the instructions given in this guide.

To validate the guarantee, please return your completed registration card within 30 days of product installation.

Within the guarantee period we will resolve defects, free of charge, by repairing or replacing parts or modules as we may choose.

To be free of charge, service work must only be undertaken by Mira Showers or our approved agents.

Service under this guarantee does not affect the expiry date of the guarantee.

The guarantee on any exchanged parts or product ends when the normal product guarantee period expires.

### Not covered by this guarantee:

Planned maintenance, or replacement parts required to comply with the servicing requirements of the TMV 2 and TMV 3 healthcare schemes (where applicable).

Damage or defects arising from incorrect installation, improper use or lack of maintenance, including build-up of limescale.

Damage or defects if the product is taken apart, repaired or modified by any persons not authorised by Mira Showers or our approved agents.

This guarantee is in addition to your statutory and other legal rights.

## What to do if something goes wrong

If when you first use your shower, it doesn't function correctly, first contact your installer to check that installation and commissioning are satisfactory and in accordance with the instructions in this manual. We are on hand to offer you or your installer any advice you may need.

Should this not resolve the difficulty, simply contact our Customer Services Team who will give every assistance and, if necessary, arrange for our service engineer to visit. If the performance of your shower declines, consult this manual to see whether simple home maintenance is required. Please call our Customer Services Team to talk the difficulty through, request a service under guarantee if applicable, or take advantage of our comprehensive After-Sales service.

As part of our quality and training programme calls may be recorded or monitored.

Our Customer Services Team is comprehensively trained to provide every assistance you may need: help and advice, spare parts or a service visit.

## Spare Parts

We maintain an extensive stock of spares and aim to provide support throughout the product's expected life.

Genuine Mira spares can be purchased direct from Customer Services or from approved stockists or merchants (locations on request).

Spare parts will normally be despatched within two working days. Payment can be made using most major Credit or Debit cards at the time of ordering. Should payment by cheque be preferred, a pro-forma invoice will be sent.

All spares are guaranteed for 12 months from date of purchase. Spares that have been supplied directly from us can be returned within one month from date of purchase, providing that they are in good order and the packaging is unopened.

**Note!** Returned spares will be subject to a 15% restocking charge and authorisation must be obtained before return. Please contact our Customer Services Team.

**Note!** In the interests of safety, spares requiring exposure to mains voltages must only be fitted by competent persons.

## Service / Repairs

Our Service Force is available to provide a quality service at a reasonable cost. You will have the assurance of a Mira trained engineer/agent, genuine Mira spare parts and a 12 month guarantee on the repair.

Payment should be made directly to the engineer/agent who will accept most major Credit or Debit cards or a cheque supported by a banker's card.

## To Contact Us

England, Scotland, Wales and Northern Ireland

### Mira Showers Customer Services

Telephone: 0870 241 0888, Mon to Fri 8:00 am - 5:30 pm  
Sat 8:30 am - 3:30 pm

E-mail: [technical@mirashowers.com](mailto:technical@mirashowers.com)  
Fax: 01242 282595  
By Post: Cromwell Road, Cheltenham,  
Gloucestershire, GL52 5EP

### Eire

#### Modern Plant Ltd (Dublin)

Telephone: 01 459 1344, Mon to Fri 9:00 am - 5:00 pm  
E-mail: [sales@modernplant.ie](mailto:sales@modernplant.ie)  
Fax: Dublin 01 459 2329  
Post: Otter House, Naas Road,  
Clondalkin, Dublin 22

#### Modern Plant (Cork)

Telephone: 021 496 8755, Mon to Fri 9:00 am - 5:00 pm  
E-mail: [cork@modernplant.ie](mailto:cork@modernplant.ie)  
Fax: 021 496 8607  
Post: Tramore Road, Cork



Mira is a registered trade mark of  
Kohler Mira Limited.

The company reserves the right to alter  
product specifications without notice.

[www.mirashowers.com](http://www.mirashowers.com)

**mira**  
SHOWERS



FM 14648