

Mira Enthuse

8.5, 9.5, 10.8 kW

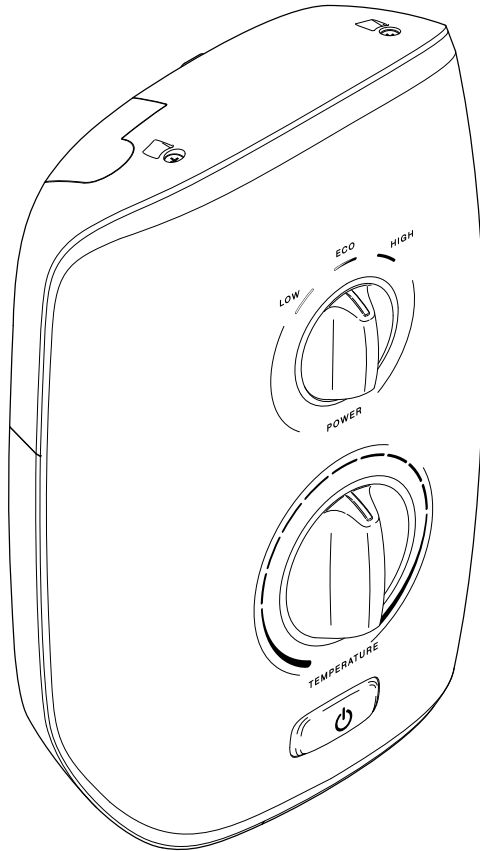

These instructions must be left with the user

Installation and User Guide

Showering perfection

mira
SHOWERS

INTRODUCTION

Thank you for purchasing a quality Mira Enthuse Electric Shower. To enjoy the full potential of your new shower, please take time to read this guide thoroughly, and keep it handy for future reference.

Products manufactured by Kohler Mira Ltd are designed to be safe provided, that they are installed used and maintained in good working order, in accordance with our instructions and recommendations.

Mira Enthuse electric showers have separate controls for power selection and for temperature/flow adjustment. A unique flow regulator stabilises any temperature changes caused by water pressure fluctuations, which can result from taps being turned on or off or toilets being flushed.

Products covered by this guide:

Product	Model Number	Colour
Mira Enthuse 8.5	J06S	White/Chrome
Mira Enthuse 9.5	J06T	White/Chrome
Mira Enthuse 10.8	J06U	White/Chrome

Guarantee

The Mira Enthuse has been designed for domestic use only, Mira Showers guarantee the Mira Enthuse against any defect in materials or workmanship for a period of two years from the date of purchase (shower fittings for one year).

For terms and conditions, refer to the back cover of this guide.

Patents and Design Registration

Design Registration:	001280135 - 0001 001280135 - 0002
Patents:	GB: 2 427 460
Patent Application:	Ireland: 2006/0462

If you experience any difficulty with the installation of your new shower, then please refer to “**Fault Diagnosis**”, before contacting Kohler Mira Limited. Our telephone and fax numbers can be found on the back cover of this guide.

IMPORTANT SAFETY INFORMATION

WARNING - This shower can deliver scalding temperatures if not operated, installed or maintained in accordance with the instructions, warnings and cautions contained in this guide and on or inside the appliance.

TO REDUCE THE RISK OF FIRE, ELECTRIC SHOCK OR INJURY:

1. Installation of this shower must be carried out in accordance with these instructions by qualified, competent personnel.
2. Isolate the electrical and water supplies before commencing installation. The electricity must be isolated at the consumer unit and the appropriate circuit fuse removed, if applicable. Mains connections are exposed when the cover is removed.
3. **DO NOT** install the shower in areas with high humidity and temperature (i.e. steam rooms and saunas).
4. **DO NOT** install the shower where it may be exposed to freezing conditions. Ensure that any pipework that could become frozen is properly insulated.
5. **DO NOT** switch the shower on if there is a possibility that the water in the shower is frozen.
6. **DO NOT** switch the shower on if water starts leaking from the shower case. Isolate the electrical supply to the shower immediately.
7. **DO NOT** connect the outlet of the shower to any tap, control valve, trigger handset or showerhead other than those specified for use with this shower. Only Kohler Mira recommended accessories should be used.
8. The water supplies to this product must be isolated if the product is not to be used for a long period of time. If the product or pipework is at risk of freezing during this period they should also be drained of water.
9. **DO NOT** perform any unspecified modifications to the shower or its accessories. When servicing only use genuine Kohler Mira replacement parts.
10. If the shower is dismantled during installation or servicing then upon completion the product must be inspected to ensure all electrical connections are tight and that there are no leaks.
11. Read all installation instructions before installing this shower.
12. Upon completion of the installation, make sure that the user is familiar with the operation of the shower, and leave this guide and the user guide with the owner.
13. Make sure that you fully understand how to operate this shower before use, read all operating instructions and retain this guide for future reference.
14. This shower is not intended for use by persons (including children) with reduced physical, sensory or mental capabilities, or lack of experience and knowledge, unless they have been given supervision or instruction concerning the use of the shower by a person responsible for their safety.

15. Children should be supervised to ensure that they do not play with the shower.
16. **DO NOT** switch the shower on if the case appears to be damaged or incorrectly fitted. Isolate the electrical supply to the shower immediately.
17. Switch off the appliance at electrical isolating switch when not in use. This is for safety and is recommended with all electrical appliances.
18. Always check the water temperature before entering the shower. Sunburn or skin conditions can increase your sensitivity to hot water. Make sure that you set the shower to a cooler temperature.
19. **DO NOT** operate the temperature control rapidly, allow 10 – 15 seconds for the temperature to stabilise before use.
20. Care is required if the shower is turned off and back on during showering as this may result in unstable temperature. Ensure temperature has stabilised before re-using shower.
21. The showerhead must be de-scaled regularly, refer to the user maintenance section towards the rear of this guide for details.
22. The shower hose must be checked regularly and replaced if damaged, refer to the user maintenance section towards the rear of this guide for details.
23. The shower must be operated and maintained in accordance with the requirements of this guide.
24. If any of the following conditions occur, isolate the electricity and water supplies and contact Kohler Mira Customer Service.
 - If the case is damaged or the cover is not correctly fitted and water has entered the shower case.
 - If the shower begins to make an odd noise, smell or smoke.
 - If the shower shows signs of a distinct change in performance indicating a need for maintenance.

PACK CONTENTS

Tick the appropriate boxes to familiarise yourself with the part names and to confirm that the parts are included.

Mira Enthuse 8.5 kW, 9.5 kW or 10.8 kW Electric Shower

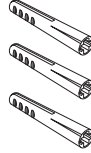
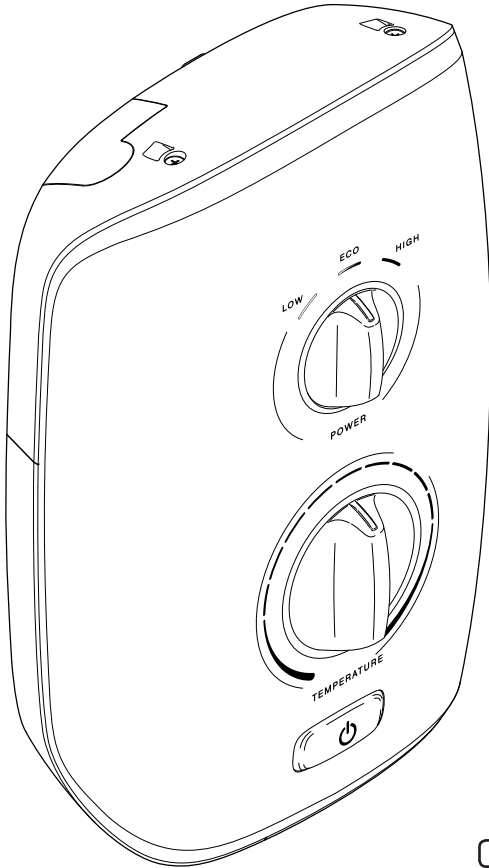

3 x Wall Plugs



3 x Fixing Screws

1 x Mira Enthuse Electric Shower

Documentation

- 1 x Installation and User Guide
- 1 x Installation Template
- 1 x Guarantee and Registration Document

Wiring Diagram

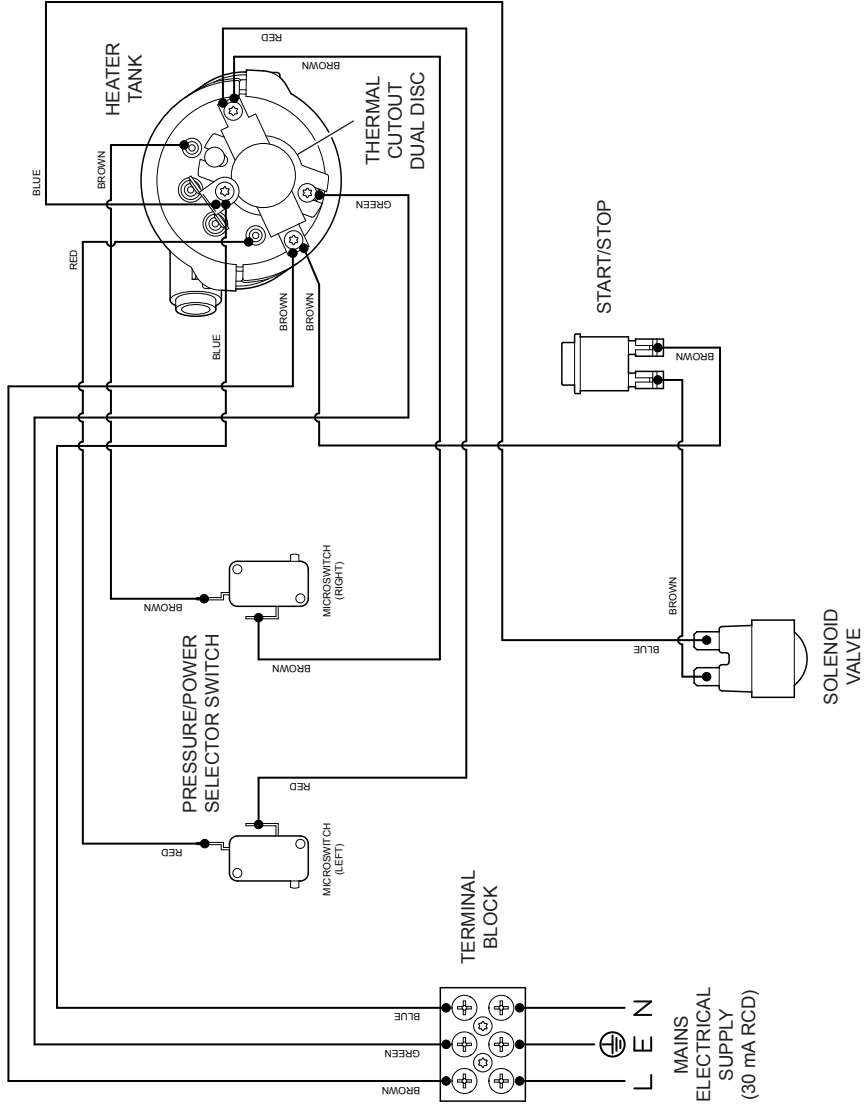

SPECIFICATIONS

Plumbing	Variant		
	Enthuse 8.5	Enthuse 9.5	Enthuse 10.8
Minimum Dynamic Pressure	70 kPa (0.7 bar)	70 kPa (0.7 bar)	100 kPa (1.0 bar)
Maximum Static Pressure	1000 kPa (10 bar)		
Minimum Static Pressure	50 kPa (0.5 bar)		
Maximum Inlet Temperature	30°C		
Minimum Inlet Temperature	2°C		
Inlet Connection	15 mm Compression / Pushfit Coupling		
Maximum Water Hardness	200 ppm CaCO ₃		
Outlet Connection	1/2" BSP Male		

Electrical	Variant		
	Enthuse 8.5	Enthuse 9.5	Enthuse 10.8
Nominal Power at 240 V ac	8.5 kW	9.5 kW	10.8 kW
Nominal Power at 230 V ac	7.8 kW	8.7 kW	9.9 kW
Recommended MCB Rating	40 A	45 A	45 A
Maximum Supply Cable Size	16 mm ²		
Recommended RCD Rating	30 mA tripping current		
Recommended Isolator Switch	45 A double-pole with 3 mm contact separation		
Appliance Sealing Rating	IP X4 - Suitable for installation in Zone 1		
Maximum Ambient Temperature	30°C		
Minimum Ambient Temperature	2°C		

Dimensions	
Height	320 mm
Width	205 mm
Depth	100 mm

European Conformity Information

The Mira Enthuse range of showers complies with the following European directives: 2006/95/EC Low Voltage Directive, 2004/108/EC EMC Directive. The Mira Enthuse range of showers are high power appliances and are subject to conditional connection. If the main electrical supply fuse is rated less than 80 Amps, the local electricity supply company must be contacted to confirm if the electrical supply is adequate. The Mira Enthuse range of showers complies with the requirements of the UK's water regulations.

INSTALLATION REQUIREMENTS

Please read the Important Safety Information, Specifications and the requirements detailed in this section before installing the shower.

WARNING - TO REDUCE THE RISK OF FIRE, ELECTRIC SHOCK OR INJURY:

Plumbing

1. The plumbing installation must comply with all national or local water regulations and all relevant building regulations, or any particular regulation or practice specified by the local water supply company.
2. **DO NOT** install the product in a position in which service access is limited.
3. Decide on a suitable position for the shower (minimum distance of 200mm from the ceiling to allow for cover fit and removal).
4. The position of the shower and shower fittings must provide a minimum gap of 25mm between the shower head and the spill over level of any bath, shower tray or basin and a minimum gap of 30mm between the shower head and the spill over level of any toilet, bidet or other appliance with a Fluid Category 5 backflow risk (see diagram).
5. The shower is suitable for installation within the shower area and is fitted with a pressure relief valve. It must be positioned over a water catchment area with the controls at a convenient height for the user.
6. The shower must be fitted to a flat, even and waterproof surface.
7. **DO NOT** fit the shower to the wall and then tile up to the case.
8. **DO NOT** seal the gap between the shower and the wall surface.
9. The shower head should be positioned so that it discharges down the centre line of a bath or across the opening of a shower cubicle.
10. **The shower head must not spray water directly on to the shower unit during normal use.**
11. **DO NOT** apply excessive force to plumbing connections; always provide mechanical support when making plumbing connections. Any soldered joints should be made before connecting the shower.
12. This inlet fitting is not designed to be connected directly from the rear. For a rear entry inlet supply, add an elbow to the supply pipe and connect as a rising or falling supply.
13. If the pipework and/or electrical cables enter the shower from the rear through a hole in the wall, provision must be made to prevent water ingress back into the wall structure.
14. Only use the inlet connector supplied with the shower. **DO NOT** use any other type of fitting.
15. A full bore/non restrictive servicing valve must be fitted in a readily accessible position adjacent to the shower to isolate the water supply for maintenance. **DO NOT** use a valve with a loose washer plate (jumper) as this can lead to a high build up of static pressure.

16. A water treatment device should be installed where the water hardness may exceed 200 ppm. Malfunctions caused by excessive limescale formation are not covered by the shower's guarantee (see back cover for details).
17. The installation must not cause the hose to be sharply kinked during normal use.
18. **DO NOT** perform the electrical installation until the plumbing has been completed and checked for leaks.

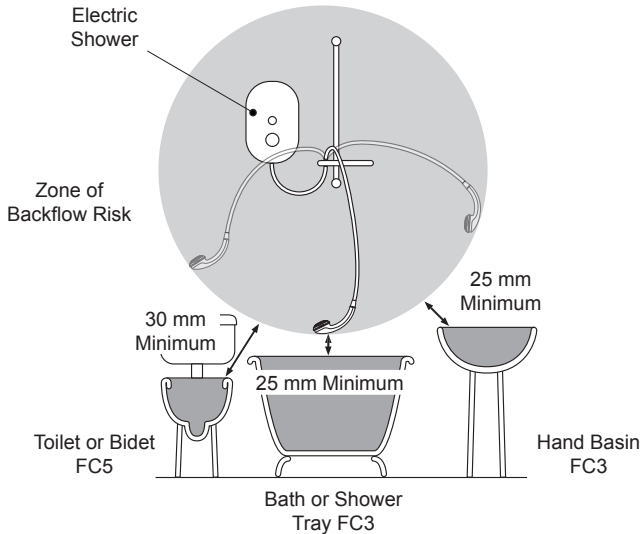

Hose Retaining Ring fitted and shower fittings fixed at a suitable height preventing unclean water backflow.

Note!

There will be occasions when the hose retaining ring will not provide a suitable solution for Fluid Category 3 installations. In these instances a double checkvalve such as the **Mira DCV-H Outlet Double Check Valve** (see 'Accessories') must be fitted between the outlet of the shower unit and the hose, the required supply pressure will need to be increased typically by 10kPa (0.1 bar). For Fluid category 5 installations, double checkvalves are not suitable.

DO NOT fit double checkvalves to the inlet supply of the shower. This will cause a static pressure build up and damage the shower and/or the plumbing system.

WARNING - TO REDUCE THE RISK OF FIRE, ELECTRIC SHOCK OR INJURY:

Electrical

1. The electrical installation must comply with BS 7671 (commonly referred to as the IEE Wiring Regulations) and all relevant building regulations, or any particular regulation or practice specified by the local electricity supply company.
2. Make sure that all circuit protection devices, switches and cables are adequate for the rated current of the shower and that the rating of the electricity supply company fuse and the consumer unit are adequate for the additional demand. (See 'Specifications - Electrical'.)
3. The shower **must** be earthed. Make sure any supplementary bonding complies with the relevant regulations.
4. The shower is intended to be permanently connected to the fixed electrical wiring of the mains system. A separate supply **must** be provided from the consumer unit to the shower.
5. **DO NOT** connect any other electrical equipment including extractor fans or pumps via the shower.
6. The shower must be provided with means for local disconnection that is incorporated into the fixed wiring in accordance with the relevant local wiring regulations. This **must** be a double pole switch, which has at least 3mm contact separation in each pole. The switch can be a ceiling mounted pull-cord type within the shower room or a wall mounted switch fitted in the applicable zone area.
7. **DO NOT** excessive force to the terminal block.
8. All electrical connections should be tightened sufficiently to prevent overheating before switching on the electrical supply.
9. **DO NOT** switch on the electrical supply until the plumbing has been completed and checked for leaks.

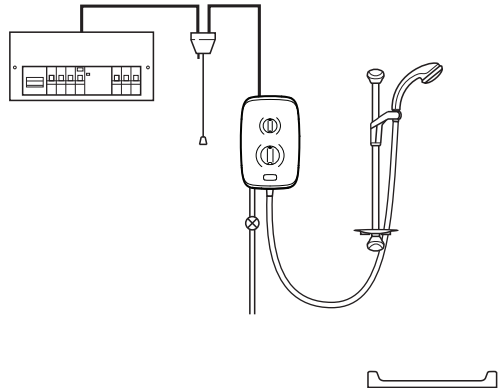

Plumbing and Electrical Schematic

INSTALLATION

Warning! Isolate the electrical and water supplies before commencing installation. The electricity must be turned off at the mains and the appropriate circuit fuse removed, if applicable.

DO NOT turn-on the electrical supply until the plumbing has been completed.

1 Determine a position for the shower, at least 200 mm from the ceiling.

2 Put the installation template on the wall and mark the positions of the **top two** fixing holes. Make sure that there are sufficient lengths of supply pipe and electrical cable to reach the connection points as shown on the template.

3 Remove the installation template and drill the **top and side** fixing holes. Insert the supplied wall plugs.

Caution! Do not drill into cables or pipes in the wall.

4 **Thoroughly flush the supply pipe.**

5 On the shower, turn the Power Setting and Temperature Control to the full anti-clockwise position (full cold).

6 Remove the three retaining screws that hold the cover on the shower and remove the cover.

7 Remove the service tunnel from the shower.

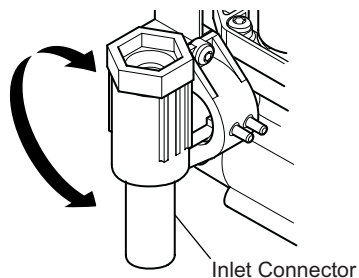
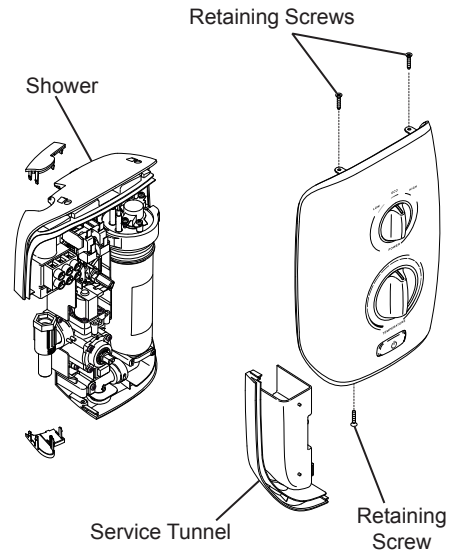
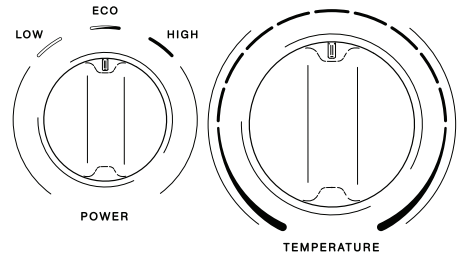

8

Determine the direction of the incoming water supply: falling (entering the shower from the top), or rising (entering the shower from the bottom).

Do not use an incoming supply entering the shower directly from the back. Add an elbow to the supply pipe and connect it as a rising or falling supply.

9

Rotate the inlet connector to suit the direction of the incoming water supply.

10

Plastic Inserts are provided to finish the top of the case as required. Can accommodate sizes up to 20 mm electrical cable trunking. Break the inserts as necessary to accommodate pipework or electrical cable trunking.

11

Secure the shower to the wall **loosely** through the top and side fixing holes, using the supplied screws.

Mark the position of the bottom fixing hole.

12

Remove the shower from the wall. Drill the bottom fixing hole and insert the supplied wall plug.

13

Replace the shower on the wall and secure through the three fixing holes, using the supplied screws.

14

Thoroughly flush the mains-fed cold water supply pipe. The

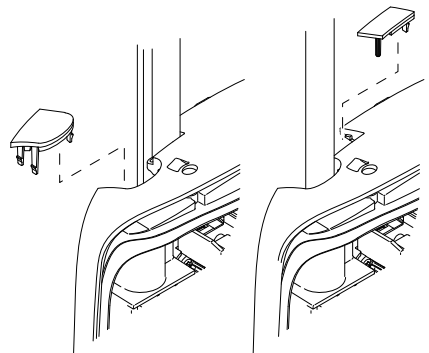
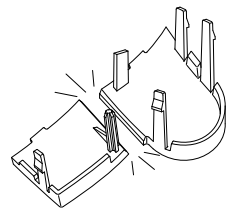
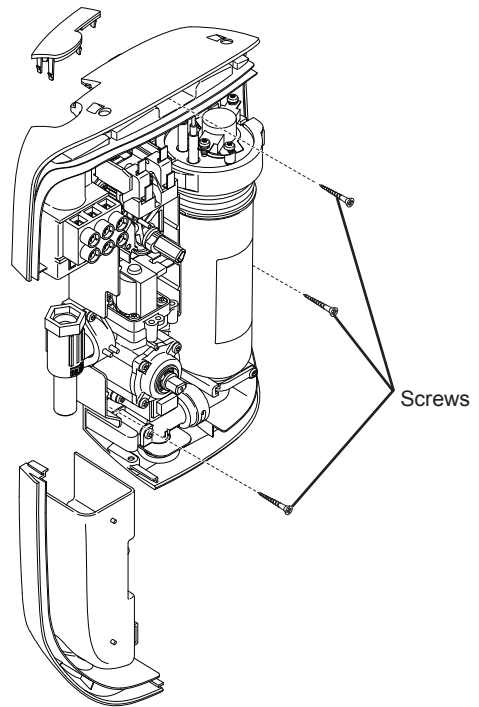

supply must be clean and free from debris BEFORE connecting the appliance.

15 Connect the inlet supply pipe to the inlet connector using a 1/2" BSP nipple with compression nuts and olives (as shown) or a push-fit connector. Check connection for leaks.

16 Bring the electrical cables into the case.

17 Strip a short section of the electrical cables.

18 Fit an earth sleeve to the earth wire.

19 Loosen the screws in the terminal block and insert the bare wires into the clamps:

L (Live) = Brown Wire

E (⏏) (Earth) = Green

Sleeved Wire

N (Neutral) = Blue Wire

Note! Do not twist the cores of the wires or strain the cables to make them reach the terminal block.

20 Tighten the screws in the terminal block so that they securely clamp the bare wires.

21 If necessary, fit an earth bonding clamp to the supply pipe and make sure that the bonding complies with the relevant regulations in force at the time of installation.

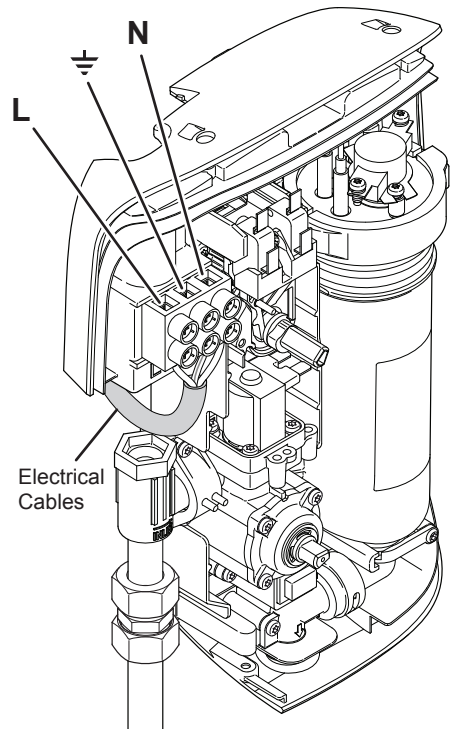
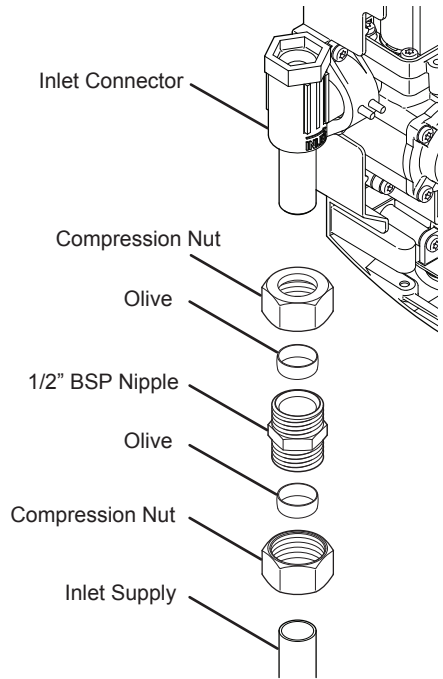

Refit the service tunnel.

22

Refit the cover. If the cover does not fit easily, rotate the controls slightly so that they fit onto the spindles. Do not force the cover.

23

Tighten the three retaining screws.

24

Install the shower fittings, refer to your Shower Fittings Installation and User Guide.

25

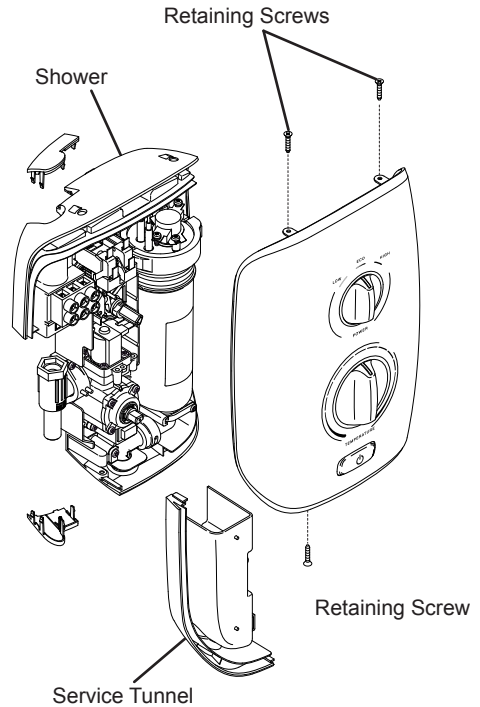

COMMISSIONING

Caution! If you are unsure how electric showers work, please read the **Operation** section before continuing.

1 Turn the shower OFF by pressing the START/STOP button. Make sure that the button is in the OFF position.

2 Turn the TEMPERATURE CONTROL fully anticlockwise to cold and the POWER SETTING to low.

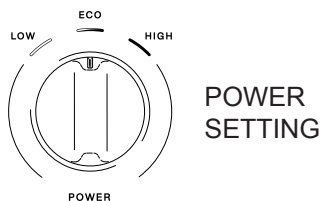

3 Turn on the water supply fully at the isolating valve. Check that water is not leaking from the bottom of the case.

4 Switch on the electrical supply at the double pole switch.

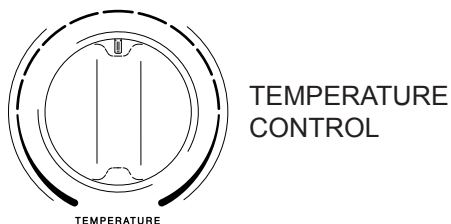

5 Turn the shower ON by pressing the START/STOP button.

Check that water flows freely from the shower within a few seconds. If not, refer to the **Servicing** section.



The water from the handset should be at full force and at a cool temperature.

6 Turn the TEMPERATURE CONTROL slowly clockwise to hot. The flow will be reduced and the temperature will remain cool (this is testing that the flow regulator is operating correctly).

7 Turn the TEMPERATURE CONTROL back fully anticlockwise to cold.

8 Turn the POWER SETTING to **Eco**. The temperature of the water should rise slightly. Allow a few seconds for the water warm fully (this shows that the heater tank is operating at half power correctly).

9 Turn the POWER SETTING to **High**. The temperature of the water will rise further (this shows that the heater tank is operating at full power correctly).

10 Set the shower temperature by rotating the TEMPERATURE CONTROL as necessary. Turn clockwise for warmer water and anticlockwise for cooler

water. Allow approximately 5 - 10 seconds for the adjusted temperature to reach the handset.

Note! It is normal for the flow rate to change when the temperature is changed.

11

When the required temperature is reached, press the START/STOP button to switch the shower OFF. Residual water may drain over a few minutes. The shower is now set for future operation.

12

Switch off the electrical supply at the double pole switch.

Note! It is normal for the shower to make a slight hissing sound during operation. High mains water pressure and high shower temperatures will affect the tone.

OPERATION

Read the section “**IMPORTANT SAFETY INFORMATION**” first.

1



Switch on the electrical supply.

2

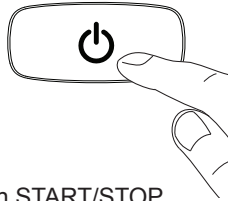

Push START/STOP button.

3

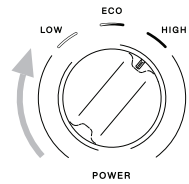

Turn power setting to the desired position.

4

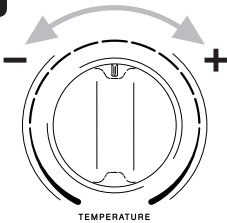

Adjust temperature as required.

5

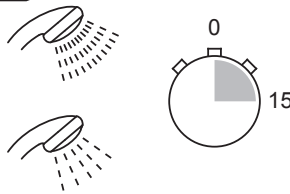

Allow 10 - 15 secs for any temperature adjustments to stabilise and reach the showerhead.

6

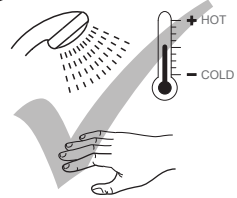

Check water temperature before entering shower.

7

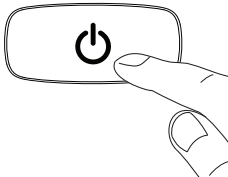

Push START/STOP button.

8



Switch off the electrical supply.

9



A small amount of water may continue to drain over a few minutes.

WARNING! Turning the shower off and back on while showering may result in unstable temperatures at the showerhead. Always ensure the temperature has stabilised before re-using the shower.

Note A slight hissing sound may be heard from the shower during operation. High mains water pressure and high shower temperatures will affect the tone. This is quite normal in use.

The Effect of Seasonal Changes

Incoming mains water temperature is not constant throughout the seasons of the year i.e. cooler during the winter, warmer during the summer, these changes can affect the outlet temperature of the shower, therefore the shower temperature may need to be increased or decreased to maintain the desired showering temperature.

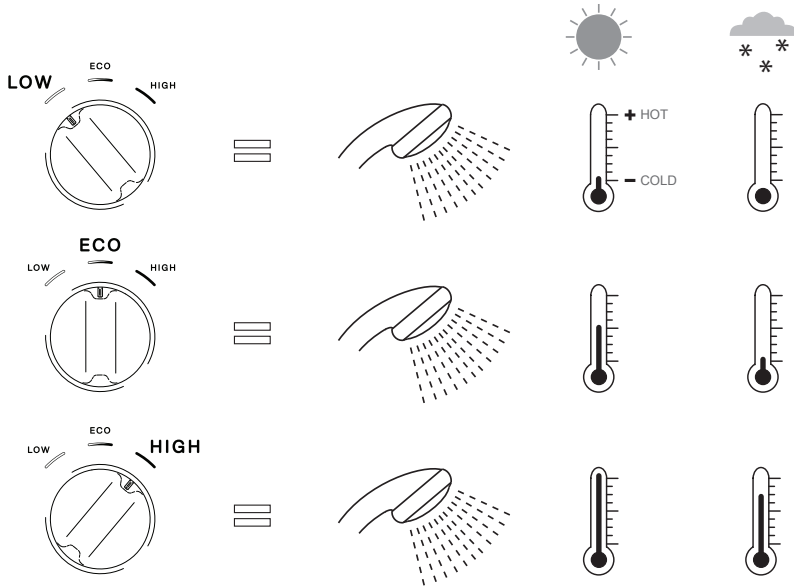

- For a cool shower select ECO
- For a summer warm shower select ECO/HIGH
- For a winter warm shower select HIGH
- Adjust the temperature as required
- The flow rate will adjust automatically

The Effect of Other Water Devices

Example of how shower temperature stabilises due to pressure changes.

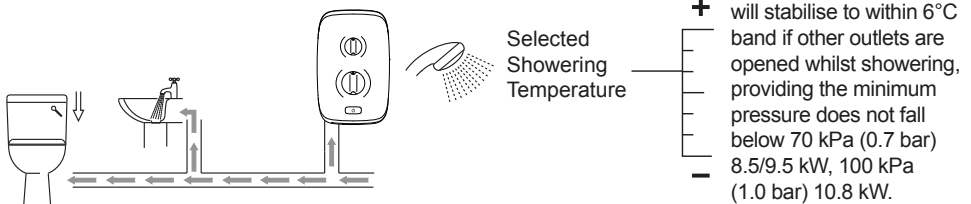

Water inlet pressure fluctuations due to other draw offs (e.g. flushing toilet) will cause the showering temperature to increase.

USER MAINTENANCE

In the event of a malfunction of the shower, a fault finding table is provided in this guide detailing possible causes and remedies that may be carried out by non-qualified personnel.

WARNING - TO REDUCE THE RISK OF FIRE, ELECTRIC SHOCK, INJURY OR PRODUCT DAMAGE:

- There are no user serviceable parts inside the shower. Only qualified, competent personnel should remove the front cover, mains connections are exposed when the cover is removed.
- Switch the shower off at the isolator switch before performing any user maintenance or before cleaning the shower.
- **DO NOT** allow young children to perform user maintenance including cleaning of the shower.
- **DO NOT** use the showerhead to clean the shower.
- If the shower is not to be used for a long period, the electrical supply and water supply to the shower should be isolated. If the shower or pipework is at risk of freezing during this period a qualified, competent person should drain them of water.

Cleaning

Many household cleaners contain abrasives and chemical substances, and should not be used for cleaning plated or plastic fittings. These finishes should be cleaned with a mild washing up detergent or soap solution, and then wiped dry using a soft cloth.

De-scaling the Showerhead

Important! Keeping the showerhead clean and free from limescale will ensure that your shower and showerhead continue to perform to their maximum. A blocked showerhead can restrict the flow rate and may cause damage to your shower

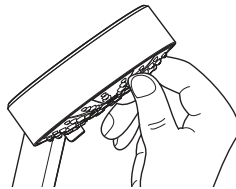

Use your thumb or a soft cloth to wipe any limescale from the soft nozzles

Inspecting the hose.

Important! The shower hose should be inspected periodically for damage or internal collapse, internal collapse can restrict the flow rate from the showerhead and may cause damage to the shower. Remove the shower hose from the shower, inspect and replace the hose if necessary.

Unscrew the hose from the showerhead and the shower outlet.

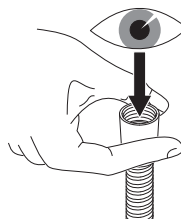

Inspect the hose.

FAULT DIAGNOSIS

The troubleshooting information tabled below gives you details on probable causes and remedies should difficulties be encountered whilst the shower is in operation.

Warning! There are no user serviceable components beneath the cover of the appliance.

ONLY A COMPETENT TRADESPERSON SHOULD REMOVE THE FRONT COVER!

Symptom	Possible Cause	Possible Remedy
Shower is too hot during the summer.	The incoming water is warmer in the summer, so the power setting is too high.	Turn the power setting to Eco and adjust the temperature control until the desired temperature is reached.
Shower is too hot even when power is set to ECO and the temperature is reduced.	The handset sprayplate is blocked.	Regularly clean the handset sprayplate.
Turning the temperature control does not affect the water temperature.	The handset sprayplate is blocked.	Remove and clean the handset sprayplate. If the fault persists, contact the shower installer.
The water continues to flow when the double pole switch is turned off.	Broken diaphragm.	Contact your installer to replace the flow valve assembly.
No water or very low flow rate.	The handset sprayplate is blocked.	Clean the handset sprayplate.
	The incoming water supply stop valves, or the appliance isolating valve, is closed.	Open the stop/isolating valve completely.
	The hose or handset is blocked.	Clear the blockage or replace the hose or handset.
	The power is off at the double pole switch.	Switch on the power at the double pole switch.
	The fuse is blown or the MCB/RCD has been tripped, indicating a possible electrical fault.	Renew the fuse or reset the MCB/RCD. If the fault persists, contact the shower installer.

Symptom	Possible Cause	Possible Remedy
	Water supply failure.	Check all isolator valves and mains stopcock are fully open.
No hot water from shower, with the controls in any position.	Other water outlets are being used during showering, causing the water pressure to drop below the minimum required. The water pressure is below the minimum required. Failure of the pressure switch, the micro switch or the thermal switch.	Make sure the other water outlets, such as the washing machine or dishwasher, are not in use during showering. Make sure that the incoming water supply stop and the isolating valve are completely open. If the fault persists, contact the shower installer. Contact installer to replace faulty parts.
The temperature cycles between hot and cold.	The temperature is set too high. This is causing the thermal switch to turn off the heating element to reduce the water temperature.	Turn the temperature control anticlockwise to reduce the water temperature.
ALL OF THE FOLLOWING REMEDIES MUST ONLY BE PERFORMED BY A COMPETENT TRADESPERSON!		
No hot water from shower, with the controls in any position.	Insufficient water supply pressure. Failure of the pressure switch, microswitch or thermal switch. An internal wiring connection has failed. One of the heater tank elements has failed. Switch assembly diaphragm fault, water dripping from the unit.	Contact the local water authority. Check the continuity of the switches, using a suitable continuity measuring device. Replace the switches as necessary. Check the integrity of the internal wiring. Replace the heater tank. Replace switch assembly.
The shower temperature cycles between hot and cold.	The temperature is set too high. This is causing the thermal switch to turn off the heating element to reduce the water temperature.	Turn the temperature control anticlockwise to reduce the water temperature. DO NOT TAMPER with the thermal switch.

(continued)

Symptom	Possible Cause	Possible Remedy
Turning the temperature control does not affect the water temperature.	<p>The flow regulator is faulty.</p> <p>The handset sprayplate is blocked.</p>	<p>Replace the flow regulator.</p> <p>Remove and clean the handset sprayplate. Refer to the shower fittings User Guide. If the fault persists, contact Customer Services.</p>
No water or very low flow rate.	<p>The handset sprayplate is blocked.</p> <p>The incoming water supply stop valves, or the appliance isolating valve, is closed.</p> <p>The hose or handset is blocked.</p> <p>Insufficient water supply pressure.</p> <p>The heater tank is excessively scaled.</p> <p>The pilot valve is faulty.</p> <p>The inlet filter is blocked.</p> <p>The power is not turned on at the double pole switch.</p> <p>The fuse is blown or the MCB/RCD has been tripped, indicating a possible electrical fault; for example, heater tank element failure.</p>	<p>Regularly clean the handset sprayplate.</p> <p>Open the stop/isolating valve completely.</p> <p>Clear the blockage or replace the hose or handset.</p> <p>Contact the local water authority.</p> <p>Replace the heater tank.</p> <p>Replace the flow regulator assembly.</p> <p>Clean the inlet filter. Refer to Servicing: Cleaning the Inlet Filter section.</p> <p>Switch on the power at the double pole switch.</p> <p>Renew the fuse or reset the MCB/RCD. If the fault persists, contact Customer Services. Replace the heater tank.</p>

Symptom	Possible Cause	Possible Remedy
Water leaks from the bottom of the case near the outlet, and there is no flow from the handset.	The pressure relief valve in the tank has been triggered, (the shower has a pressure relief valve assembly that works to reduce the damage if the outlet is blocked or the unit is frozen).	Resolve the blocked outlet, and replace the tank assembly.
The water cannot be turned off.	<p>The pilot valve is faulty.</p> <p>Broken diaphragm.</p> <p>The supply pressure is below the minimum requirement.</p>	<p>Replace the flow regulator assembly.</p> <p>Replace the flow regulator assembly.</p> <p>Contact the local water authority. Check the static water pressure. Note that the static pressure may fall below minimum requirement when other appliances are drawing water, for example the dishwasher or washing machine.</p>

SERVICING

Any servicing must be carried out by a qualified tradesperson, following the instructions provided. Before replacing any parts, make sure that the underlying cause of the malfunction has been resolved.

Warning! There are no **user-serviceable** components beneath the cover of the appliance.

ONLY A COMPETENT TRADESPERSON SHOULD REMOVE THE COVER!

Cleaning

Many household and industrial cleaners contain abrasive and chemical substances that can damage the finish of your shower. Only clean the shower and fittings with a mild washing-up detergent or soap solution, and then wipe them dry with a soft cloth.

Handset

Poor shower performance can be avoided by regular cleaning of the handset. Use your thumb or soft cloth to wipe the rubber nozzles. The handset must also be descaled regularly.

Cleaning the Inlet Filter

Warning! Isolate the electrical and water supplies before removing the cover.

- 1** Remove the three retaining screws and remove the Cover.
- 2** Remove the Service Tunnel from the Shower.
- 3** Use a suitable spanner to remove the Inlet Filter from the Inlet Connector Assembly. Hold a second spanner or suitable grips across the flats of the Inlet Connector Assembly to prevent damage to the Connector, whilst removing the Strainer. Do not remove the 'O' seal.
- 4** Remove the filter and rinse under a running tap to remove any lodged particles. If necessary, use a kettle descaler in accordance with the manufacturer's instructions.

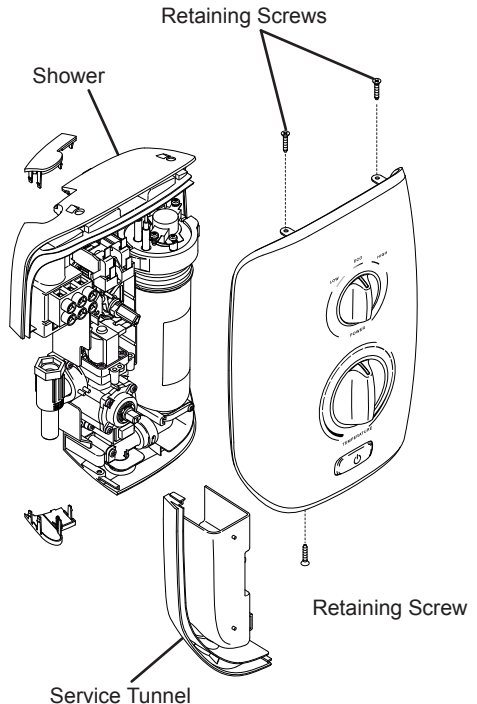

5

Refit the components in reverse order.

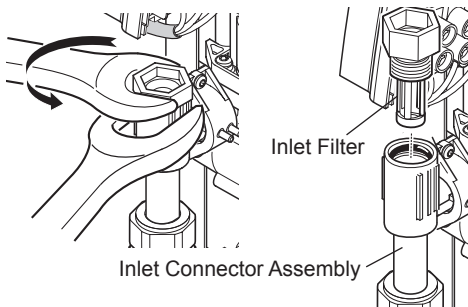

Spare Parts Diagram

439.76 Clamp Bracket Pack- identified 'A'

439.88 Seal Pack - identified 'B'

1798.062 Screw Pack - identified 'C'

1798.060 Wire Pack - identified 'D'

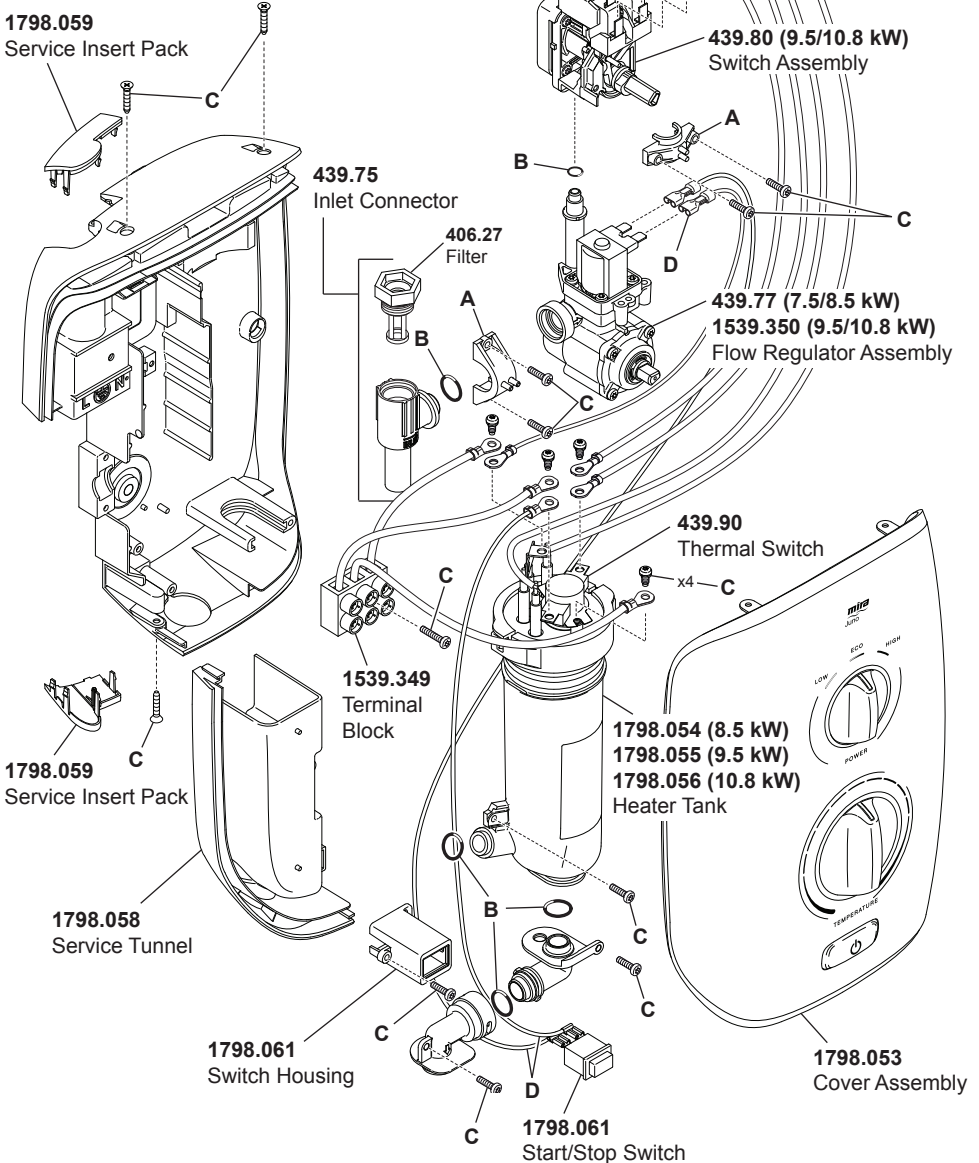

WIRE LENGTHS NOT TO SCALE

ACCESSORIES

Genuine Mira accessories can be purchased direct from Customers Services (our contact details can be found on the back cover of this guide) or from approved stockists or merchants.

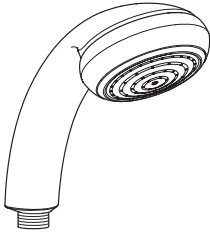

Everclear Showerhead

White - 2.1616.030

Chrome - 2.1616.031

9.5 kW and 10.8 kW versions only

Mira's new Everclear range has been specially designed for hard water areas and reduces the risk of lime scale build up.

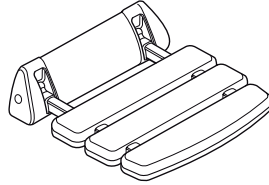

Shower Seat

White - 2.1536.128

White/Chrome - 2.1536.129

For use in or out of the showering area. **Note!** Must be installed onto a solid wall.

Shower seat folds up when not in use

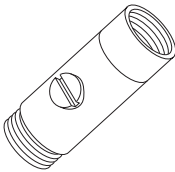

Outlet Double Check Valve (DCV-H)

Chrome - 1.0.110.55.1

DCV-H: An outlet double check valve, designed to prevent the backflow or backsiphonage of potentially contaminated water, through shower controls which are fitted with a flexible hose as part of the outlet shower fitting.

CUSTOMER SERVICE

Guarantee

Your product has the benefit of our manufacturer's guarantee which starts from the date of purchase.

To activate this guarantee, please return your completed registration card, visit our website or free phone 0800 0731248 within 30 days of purchase (UK only).

Within the guarantee period we will resolve defects in materials or workmanship, free of charge, by repairing or replacing parts or product as we may choose.

This guarantee is in addition to your statutory rights and is subject to the following conditions:

- The guarantee applies solely to the original installation under normal use and to the original purchaser only. The product must be installed and maintained in accordance with the instructions given in this user guide.
- Servicing must only be undertaken by us or our appointed representative. **Note!** if a service visit is required the product must be fully installed and connected to services.
- Repair under this guarantee does not extend the original expiry date. The guarantee on any replacement parts or product ends at the original expiry date.
- For shower fittings or consumable items we reserve the right to supply replacement parts only.

The guarantee does not cover:

- Call out charges for non product faults (such as damage or performance issues arising from incorrect installation, improper use, inappropriate cleaning, lack of maintenance, build up of limescale, frost damage, corrosion, system debris or blocked filters) or where no fault has been found with the product.
- Water or electrical supply, waste and isolation issues.
- Compensation for loss of use of the product or consequential loss of any kind.
- Damage or defects caused if the product is repaired or modified by persons not authorised by us or our appointed representative.
- Routine maintenance or replacement parts to comply with the requirements of the TMV 2 or TMV 3 healthcare schemes.
- Accidental or wilful damage.
- Products purchased ex-showroom display.

What to do if something goes wrong

If your product does not work correctly refer to this manual for fault diagnosis and check that it is installed and commissioned in accordance with our instructions.

If this does not resolve the issue, contact us for help and advice.

Extended Guarantees

A selection of protection plans are available that enable you to cover repair bills (excludes Eire). Ring 01922 471763 for more details.



Helpdesk Service - Ring our Customer Services Team for product advice, to purchase spare parts or accessories or to set up service visit. You can contact us via phone or e-mail, details below. Please provide your model name, power rating (if applicable) and date of purchase.



Mira Showers Website (www.mirashowers.co.uk)

Visit our website to register your guarantee, download user guides, diagnose faults, purchase our full range of accessories and popular spares, or request a service visit.



Spares and Accessories - We hold the largest stocks of genuine Mira spares and accessories. Contact us for a price or visit our website to purchase items from our accessory range and popular spares.



Service/Repairs - No one knows our products better than our nationwide team of Service Technicians. We can carry out service or repair work to your product both during and after the guarantee period. Ask about our fixed price service repairs.

To Contact Us: UK



0844 571 5000



Fax: 01242 282595



E-mail: Visit www.mirashowers.co.uk/contactus



Mira Customer Services Dept, Cromwell Road, Cheltenham, Gloucestershire, GL52 5EP

To Contact Us: Eire Only



01 531 9337



E-mail: CustomerServiceEire@mirashowers.com

Mira is a registered trade mark of Kohler Mira Limited.

The company reserves the right to alter product specifications without notice.

